

Technique Interior

Release July 2015

interior

for
people
who
create

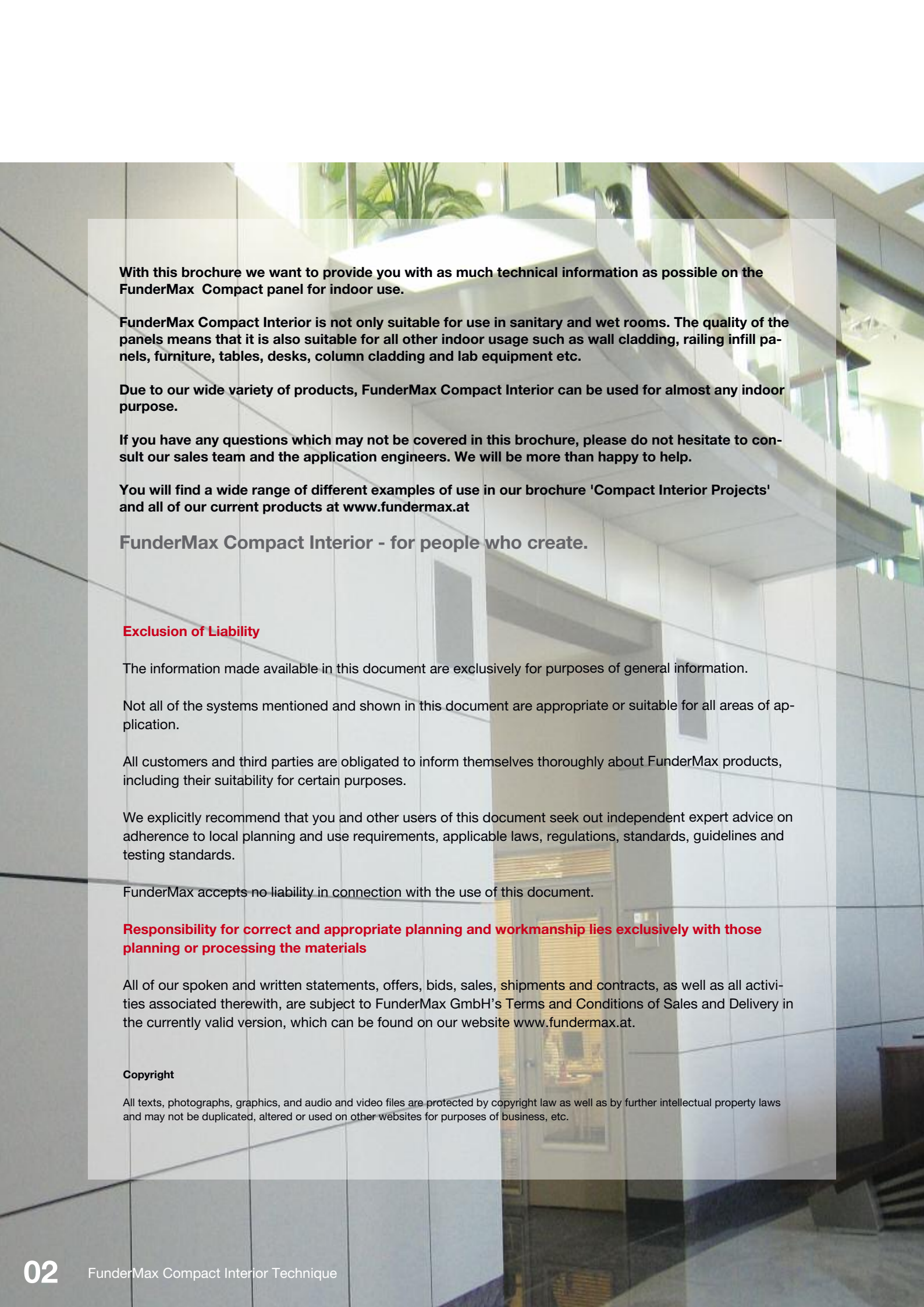

With this brochure we want to provide you with as much technical information as possible on the FunderMax Compact panel for indoor use.

FunderMax Compact Interior is not only suitable for use in sanitary and wet rooms. The quality of the panels means that it is also suitable for all other indoor usage such as wall cladding, railing infill panels, furniture, tables, desks, column cladding and lab equipment etc.

Due to our wide variety of products, FunderMax Compact Interior can be used for almost any indoor purpose.

If you have any questions which may not be covered in this brochure, please do not hesitate to consult our sales team and the application engineers. We will be more than happy to help.

You will find a wide range of different examples of use in our brochure 'Compact Interior Projects' and all of our current products at www.fundermax.at

FunderMax Compact Interior - for people who create.

Exclusion of Liability

The information made available in this document are exclusively for purposes of general information.

Not all of the systems mentioned and shown in this document are appropriate or suitable for all areas of application.

All customers and third parties are obligated to inform themselves thoroughly about FunderMax products, including their suitability for certain purposes.

We explicitly recommend that you and other users of this document seek out independent expert advice on adherence to local planning and use requirements, applicable laws, regulations, standards, guidelines and testing standards.

FunderMax accepts no liability in connection with the use of this document.

Responsibility for correct and appropriate planning and workmanship lies exclusively with those planning or processing the materials

All of our spoken and written statements, offers, bids, sales, shipments and contracts, as well as all activities associated therewith, are subject to FunderMax GmbH's Terms and Conditions of Sales and Delivery in the currently valid version, which can be found on our website www.fundermax.at.

Copyright

All texts, photographs, graphics, and audio and video files are protected by copyright law as well as by further intellectual property laws and may not be duplicated, altered or used on other websites for purposes of business, etc.

Quality	04
FunderMax Compact and the environment	07
Formats	08
Material characteristics	09
Material properties	10
Qualifications	11
Transport and storage	12
Processing recommendations	13
Chemical resistance	30
Cleaning	36
Wall cladding	38
Cubicles	56
Ceilings	70
Table tops	74
Furniture	76
Wash basins	80
Sandwich elements	83
Railings	84

The diagrams in this technical information are schematical representations and are not true to scale. This issue replaces all other issues of Exterior Techniques brochures of FunderMax which were published before.

FUNDERMAX

Compact Interior

FunderMax Compact Interior panels are high-pressure laminate panels (HPL) manufactured to standard EN 438 that are produced in laminate presses under high pressure at high temperature. They are particularly suitable for demanding and decorative applications (e.g. furniture, office furniture, wall cladding, sanitary facilities etc.).

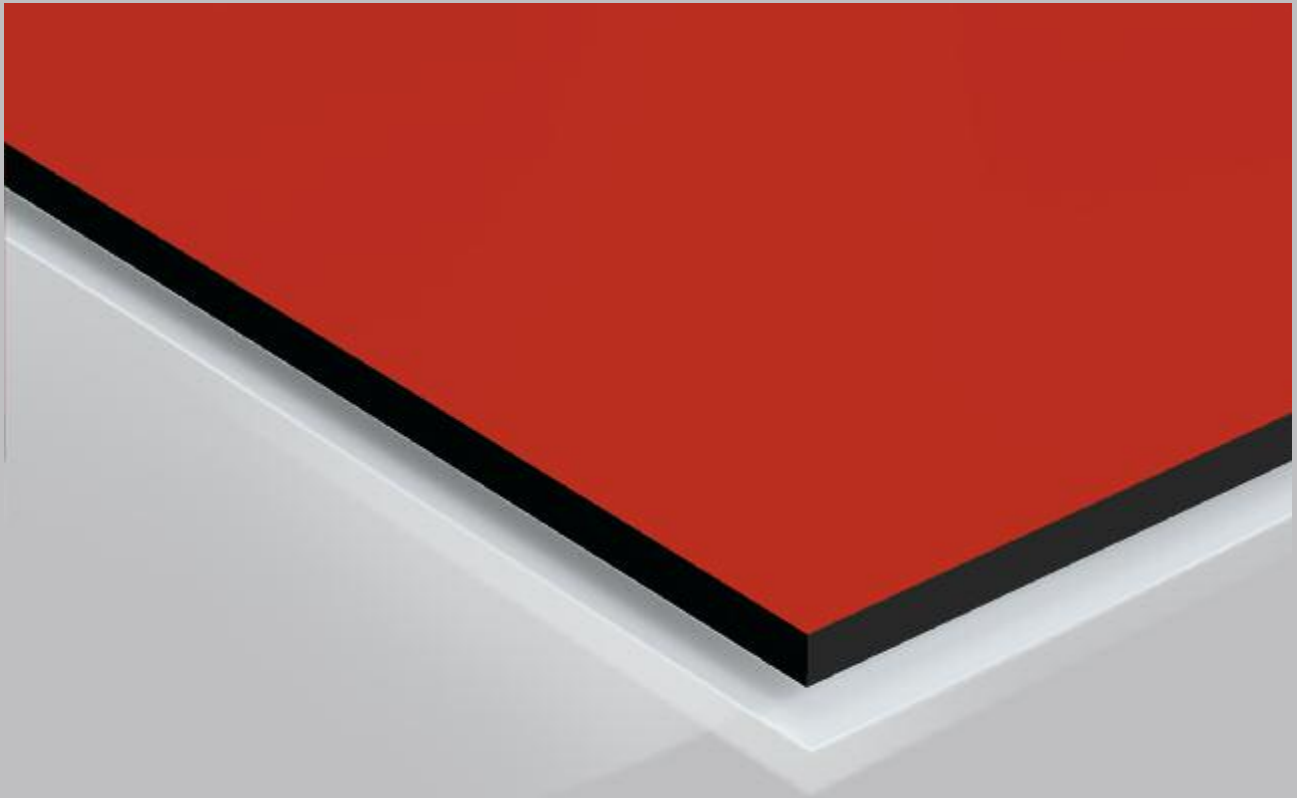
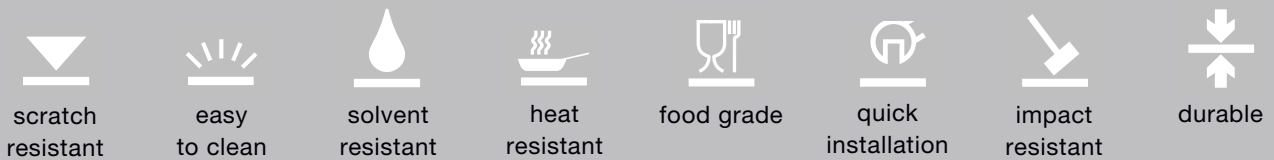

Properties*:

- __scratch resistant
- __solvent resistant
- __food grade (ISEGA 28468 v 09)
- __heat resistant
- __easy to clean
- __hygienic
- __impact resistant (EN ISO 178)
- __suitable for all interior applications
- __decorative
- __self-supporting
- __abrasion proof
- __bending resistant (EN ISO 178)
- __frost and heat resistant -80°C bis +80°C (DMTA-OFI 300.128)
- __easy to install
- __durable
- __resistant to chemicals

*Material properties you will find on page 10

Max Compact Interior

As a standard, Max Compact panels come with decors on both sides. The core is black and the surfaces are available in different structures. See our current delivery programme.



Max Compact Interior Plus

Max Compact Interior Plus panels have the same qualities as the Compact Interior and Max Alucompact, but are manufactured with a double-hardened, pore-free surface sealed with urethane acrylate for increased surface protection.

Decors - Please refer to the Decor Collection IP.



Max Resistance (Typ CGS manufactured to standard EN 438-4)

Max Resistance panels are Compact Interior panels with an integrated chemical-resistant surface.

Decor - Please refer to the Decor Collection RE.



Max Compact with White Core

Though similar in form and function, these Compact panels exhibit the fine stylish difference: The panel core remains an exquisite white. Slight colour differences to the Max Laminate panels and Max Compact panels with a black core are possible. When combining panels, please compare the samples. Decor is always the same on both sides.



Max Alucompact (42, 06)

The design is the same as the Max Compact Interior panel, but is additionally provided on both sides with aluminum bands under the decorative layers or in the core. This ensures that even perforated panels are extremely stable. Furthermore, this panel type can be used as wall cladding without rear ventilation. In furniture applications, the edges stand out as modern design elements.



Max Protect

Max Protect are Compact Interior panels with an Alpha Protect layer that provides almost 100% protection against electromagnetic radiation.



Max Compactforming Elements

Through a patented process with a special core structure, flat Max Compact Interior panels are post-formed into functional elements.



FunderMax Elements (processing)

FunderMax offers CNC controlled processing and panel cutting. With state-of-the-art devices, it is possible to produce everything: from simple cutouts for mounting the panels, to intricate milling for railing panels or furniture elements. We can make just about anything you can dream up.





Fig. 1

Natural materials

FunderMax Compact Interior panels are made primarily from wood that is processed into "kraft papers". The wood accumulates as a by product during logging or in sawmills. We procure these raw materials from suppliers that are certified under the FSC and PEFC standards. The standards confirm that the logging occurs in accordance with internationally valid rules for sustainable forestry.

Environmentally Friendly Production

The kraft paper is impregnated with resins on impregnating lines, dried and pressed at high pressure and heat into durable moisture resistant panels. The exhaust air extracted from the drying is treated by regenerative thermal oxidation in which heat produced thereby is redirected back into the process. For installing this efficient air handling FunderMax was given the best practice the "climate:active" award by the Austrian Energy Agency and the Federal Ministry for the Environment. The production plant can thus reduce its emissions by approximately 10,000 tons of CO₂ per year.

Long-lasting and maintenance-free

Extensive tests certify the exceptional durability of Compact Interior panels. The production process ensures a highly resistant surface. FunderMax Compact Interior panels do not require any maintenance to ensure a long service life. The surface of the panels is highly resistant to soiling. If necessary, they can be cleaned with standard cleaning agents. It is not necessary to seal the edges, even after cutting. The robust surface is also suitable for highly stressed applications such as ramming protection and is highly resistant to impact marks.

Disposal/Recycling

Off-cuts are energetically recycled in-house. Our state-of-the-art green electricity district heating power stations no harmful exhausts arise such as dioxin, hydrochloric acid or organic chlorine compounds. The residual ashes are free of heavy metals. Basically, the specific provincial laws and regulations concerning the disposal must be observed. In Austria, the thermal recycling of waste is preferable to landfill. The ash resulting from the thermal recycling of waste can be easily disposed of in controlled industrial landfills.

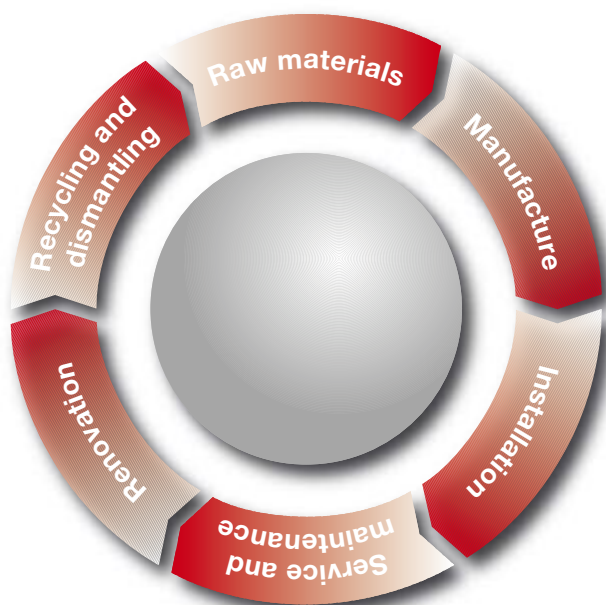

Fig. 2

Formats

In this overview you will find available sizes for FunderMax Compact Interior panels together with the different technical surfaces and product designs or, a decorative design.

We reserve the right to make changes in line with product development. Please note the FunderMax current delivery and stock programme.

Formats

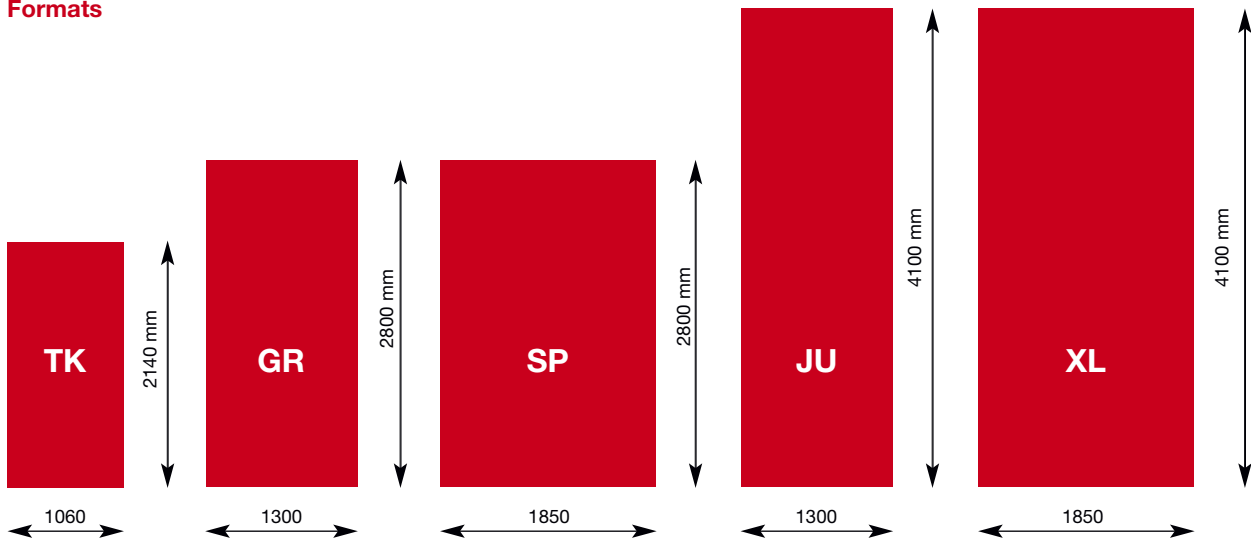

Fig. 3

available formats according to the products*)						
	TK	GR	JU	SP	OF	XL
Max Compact Interior	●	●	●	●		●
Max Compact Interior Plus	●	●	●	●		●
Max Resistance ² (Lab panels)					●	
Max Compact with Individualdekor	●	●	●			
Max Alucompact (06, 42)	●	●	●			
Max Protect	●	●	●			
Max Compact with white core			●			●
Max Compactforming Panels			●			

Table 1

*) Limited design possibilities and surfaces according to the format. Please consult our current delivery and stock programme.

Material characteristics and expansion clearance

Max Compact panels do not only react to temperature but primarily to moisture in relation to the climactic conditions of the respective storage or mounting area. If both of these influential factors affect one side of the panel only, it can lead to variations of flatness depending on the period of exposure. Please take note of our advice concerning ventilation, storage and stack coverage.

Max Compact shrinks when it loses moisture!
 Max Compact expands when it absorbs moisture!
 When working and constructing with the panels, thought must be given to this possible dimensional change. For Max Compact it is basically half as much lengthways as widthways (see properties on page 10; lengthways is relative to the nominal panel format!).

Metal substructures experience dimensional changes when exposed to variations in temperature. However, the dimensions of Max Compact also change under the influence of increasing relative air moisture. These dimensional changes of the substructures and cladding materials may work in opposing directions. Therefore, it is important to ensure sufficient room for expansion. As a general rule for necessary expansion clearance:

Element length = a
 Element width = b

$$\frac{a \text{ or } b \text{ (in mm)}}{500} = \text{Expansion clearance}$$

Temperature resistance

Max Compact Interior panels remain dimensionally stable up to 80°C of constant temperature exertion.

Max Alucompact42 and Max Alucompact06 are specially designed for use in highly fluctuating temperatures or varying climatic conditions on both sides of the panels.

Max Alucompact Arrigo, Marc, Tri and Quattro panels should not be exposed to high fluctuations of temperature and moisture (recommended use +15°C to +35°C, 30 – 70% relative to air moisture)

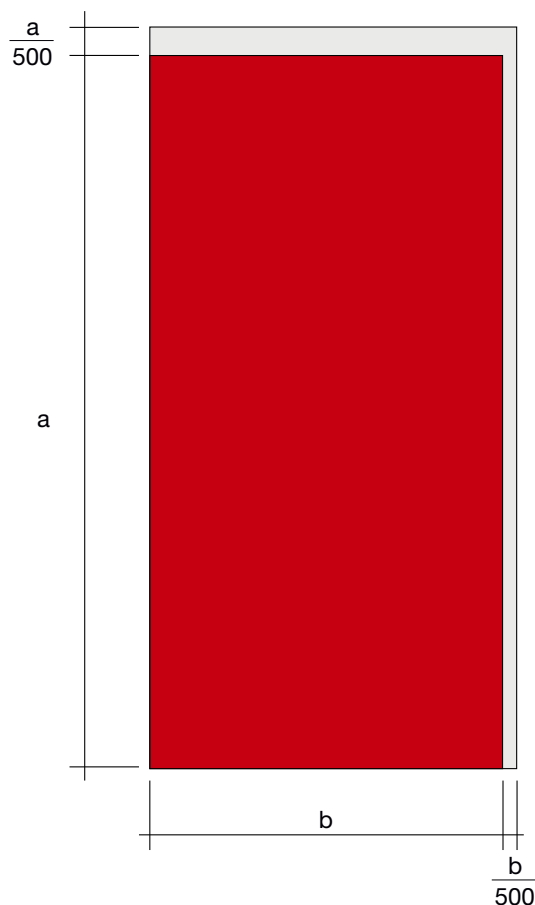

Fig. 4

Material properties

FunderMax Compact Interior Panels (HPL) acc. to EN 438

Properties tested in acc. to EN 438-2	Unit of measurement	Max Compact		Max Compact F-Quality		Max Alucompact42		Max Alucompact Arrigo		Max Alucompact Quattro		Max Compact IP		Max Compact IP F-Quality		Max Resistance		Max Alucompact42 IP		Max Compact with white core	
		Standard ¹⁾	Value ²⁾	Value ²⁾	Value ²⁾	Value ²⁾	Value ²⁾	Value ²⁾	Value ²⁾	Value ²⁾	Value ²⁾	Value ²⁾	Value ²⁾	Value ²⁾	Value ²⁾	Standard ¹⁾	Value ²⁾				
Type acc. to EN 438		CGS	CGF							CGS	CGF										

Physical data

Apparent density DIN 52350/ISO 1183	g/cm ³	≥ 1,35	≥ 1,4	≥ 1,4	ca. 1,55	ca. 1,55	ca. 1,65	≥ 1,4	≥ 1,4	≥ 1,4	1,55	≥ 1,4	1,55
Thickness (e.g.) EN 438-2, point 5	mm	10	10	10	10	10	10	10	10	10	10	10	10
Weight	kg/m ²	14,0	14,0	15,5	15,5	16,5	14,0	14,0	14,0	14,0	15,5	15,5	15,5

Mechanical properties

Resistance against stress abrasion EN 438-2, point 10	U	≥ 350	450	450	450	450	450	450	450	450	450	450	450	≥ 350	450
Falling ball impact resistance EN 438-2, point 21	mm	≤ 10	8	8					8	8	8				
Resistance against scratching EN 438-2, point 25	degr./scratch r.	≥ 3 ≥ 4 N	3 4 N	3 4 N	3 4 N	3 4 N	3 4 N	3 4 N	3 4 N	3 4 N	3 4 N	3 4 N	3 4 N	3 4 N	3 4 N
Flexural strength EN ISO 178	MPa	≥ 80	100	90	200	200	200	100	90	100	200	80	80		
E-Modulus EN ISO 178	MPa	≥ 9000	10000	9500	18000	18000	18000	10000	9500	10000	18000	9000	9000		
Tensile strength EN ISO 527-2	MPa	≥ 60	60	80				60	80	60		60	60		
Susceptibility to cracking EN 438-2, point 24		4	5	5				5		5		3	4		

Thermal properties

Dimensional changes during climatic changes, measured at elevated temperatures EN 438-2, point 17	length. %	≤ 0,3	0,05	0,15	0,15			0,05	0,15	0,05	0,15	≤ 0,5	≤ 0,5
	cross. %	≤ 0,6	0,15	0,25	0,25	*)	*)	0,15	0,25	0,15	0,25	≤ 0,8	≤ 0,8
Resistance to boiling water EN 438-2, point 12	%	≤ 2,0	0,3	0,5	0,3	*)	*)	0,3	0,5	0,3	*)		
Coefficient of thermal expansion DIN 52328	1/K		20 x 10 ⁻⁶	20 x 10 ⁻⁶				20 x 10 ⁻⁶	20 x 10 ⁻⁶	20 x 10 ⁻⁶			
Thermal conductivity I	W/mK		ca. 0,3	ca. 0,3				ca. 0,3	ca. 0,3	ca. 0,3			
Resistance to vapour diffusion			17.200μ		730.000μ			17.200μ		17.200μ	730.000μ		
Surface resistance DIN 53482	Ohm		10 ⁹ -10 ¹¹	10 ⁹ -10 ¹¹				10 ⁹ -10 ¹¹	10 ⁹ -10 ¹¹	10 ⁹ -10 ¹¹			
Resistance to cigarette burns EN 438-2, point 30	Degree	≥ 3	5 - no visible changes ³⁾									≥ 3	5
Resistance to hot soucepans EN 438-2, point 16	Degree	≥ 4	5 - no visible changes, no blisters or cracks ⁴⁾									≥ 4	5
Heating value	MJ/kg		18 - 20										

Optical properties

Light fastness no. EN 438-2, pt. 27 ⁵⁾	Level	≥ 4	≥ 4	≥ 4	≥ 4	≥ 4	≥ 4	≥ 4	≥ 4	≥ 4	≥ 4	≥ 4	≥ 4
---	-------	-----	-----	-----	-----	-----	-----	-----	-----	-----	-----	-----	-----

Table 2

Fire behavior

	Compact Interior	Compact Interior F-Quality
Reaction to fire classification		
Europe EN 13501-1 Euroclass	D-s2, d0	B-s2, d0/B-s1, d0 ⁶⁾
Austria A3800/1	Tr1, Q1	Tr1, Q1
Switzerland fire classification		5(200 ⁷⁾ 3
Germany DIN 4102	B2	B1

Table 3

¹⁾ according to EN 438

²⁾ Average values of production control

³⁾ Slight change in glossy finish, yellow or light brown colours are permitted by EN 438

⁴⁾ Slight change in glossy finish permitted by EN 438

⁵⁾ grey scals after light exposure acc. blue wool scale 6

⁶⁾ for 6-20 mm if mounted with max. gap of 15 mm acc. to classification Report MA39-VFA2014-1629

⁷⁾ These qualities are only suitable for inner lining. The panels should not be exposed to high fluctuations of temperature or moisture. (Recommended range: +15 -+35°C, 30 -70% rel. to air moisture)

For Max Compact panels types CGS and CGF, ONCERT as a global authorisation body confirms the compliance of quality standards in accordance with EN 438.

Hygiene

The sterilisability of FunderMax panel surfaces:
Institute of Hygiene at the University of Vienna

The sterilisability of Max Compact IP panel surfaces:
OFI, Field of medicine and hygiene

Sterilisability and stain resistance of FunderMax panel surfaces: Austrian Plastics Institute

Safe contact of compact panels and food products:
ISEGA-Aschaffenburg

PAK testing of FunderMax Compact and laminate panels on their content of polycyclic aromatic hydrocarbons (PAH): ISEGA-Aschaffenburg

Fire behavior

■ EU

Max Compact Panel Type CGS

Classification according to EN 13501-1: D – s2, d0

Max Compact Panel Type CGF

Classification according to EN 13501-1: B – s2, d0

Max Alucompact42 F-Quality

Classification according to EN 13501-1: B – s2, d0

■ Austria

Type CGS according to ON A3800

„schwer brennbar“, Tr1, Q1

Type CGF according to ON A3800

„schwer brennbar“, Tr1, Q1

■ Switzerland

Type CGF

Fire classification: 5(200°C).3

Basel Institute of Security

■ Germany

Type CGS

Classification according to DIN 4102-1

B 2 - „normal entflammbar“

Type CGF

Classification according to DIN 4102-1

B 1 - „schwer entflammbar“

The validity of each of the respective test certificates should be noted. You can find the current certificates on our homepage at: 'www.fundermax.at' under 'Downloads' – 'certificates/technical approvals'.

Please take note of the valid standards, regulations and guidelines for the permitted use of materials in relation to fire performance and fall protection.

Transport and Storage

Transport and Handling

Handle FunderMax Compact Interior panels with care in order not to damage the edges and surfaces of the high-quality material.

In spite of the excellent surface hardness and the installation protection film, the stack weight of FunderMax Compact Interior panels is a possible cause of damage. Therefore, any form of dirt or dust between the panels must definitely be avoided.

FunderMax Compact Interior panels must be secured against slippage during transport. When loading or unloading, the panels must be lifted. Do not push or pull them over the edge.

Transport protection films must always be removed from both sides at the same time.

The transport protection film must not be exposed to heat or direct sunshine.

Storage and Air Conditioning

must be stacked horizontally on flat, stable supports and supporting panels. The goods must lie completely flat.

Cover plates must always be left on the stack. The top cover should be weighted down.

After removal of panels, PE films must again be closed over the stack.

The same applies, in principle, for cut-panel stacks. Incorrect storage can lead to permanent deformation of the panels.

FunderMax Compact Interior panels are to be stored in closed rooms under normal climatic conditions. Climate differences on the two surfaces of a panel are to be avoided.

With pre-installed fastening elements, therefore, care is to be taken that the climatic effect is uniform on all sides. Use intermediate layers of wood or plastic.

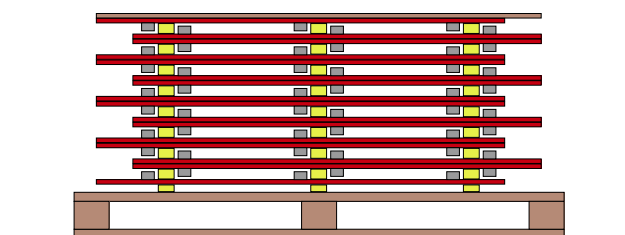

Fig. 5

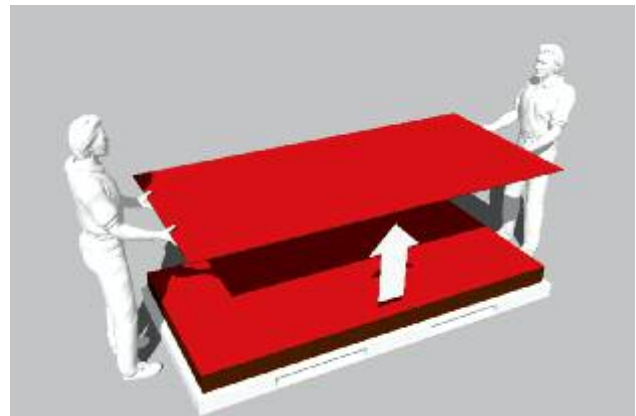

Fig. 6



Fig. 7

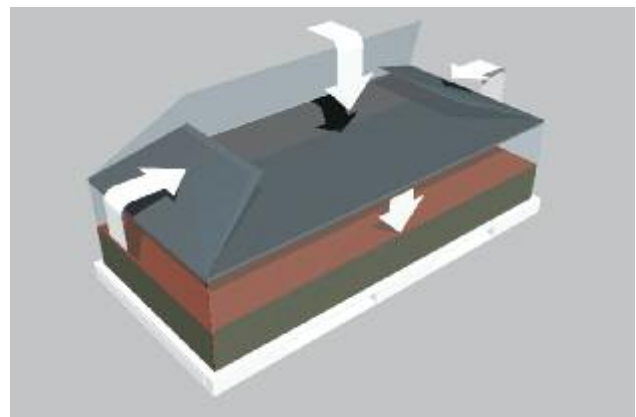

Fig. 8

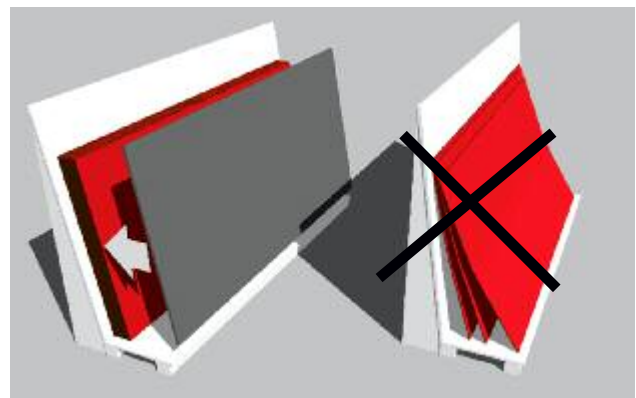

Fig. 9

The processing of FunderMax Compact panels

General

The surface area of FunderMax Compact Interior panels contains high-quality melamine resins and is therefore highly resistant. The processing properties of the FunderMax Compact Interior panels are similar to those for the processing of hardwood. Hard metal cutting tools have been tested and are indispensable when working with FunderMax Compact Interior panels. If a long tool life is required, diamond-tipped (DP) tools should be used. Sharp blades and smooth functioning are both necessary elements to ensure a faultless processing of the material. Breaking-off, splintering and chipping of the decorative side is a result of incorrect handling or unsuitable tools. Machine tables should be as flat and smooth as possible, so that no chips collect - which can damage the surface area. The same also applies for work surfaces and the controlling of hand-held machines.



Fig. 10

Safety measures

This is simply a list of the recommended personal protective equipment. The standard required protective equipment for the given field of work should be used (work clothes, safety boots, hairnets,...).

Gloves



EN 388

Mechanical risks

The higher the digit, the better the test result.

Test resistance	Digit
Abrasion	0 - 4
Blade cut	0 - 5
Tear	0 - 4
Puncture	0 - 4

Non-bevelled cut edges are sharp and pose a risk of injury. To protect against the handling of freshly cut FunderMax Compact panels, gloves of protection category II with a minimum cut resistance of 2 should be used.

Protective goggles



As with the manufacturing of any other wood, tightly-sealed eye protectors must be worn when working with FunderMax Compact.

Dust protection



As with the manufacturing of any other wood, the processing of FunderMax Compact panels can create dust. For sufficient respiratory protection, dust mask filters for e.g. should work.

Hearing protection



During the mechanical treatment of FunderMax Compact the sound level can rise to above 80dBA. Please ensure that you have adequate ear protection at all times when working with these materials.

Processing recommendations

General processing guidelines

When working with FunderMax Compact Interior panels the ratio between the number of teeth (z), the cutting speed (v_c) and the feed rate (v_f) must be observed.

	v_c	f_z
	m/s	mm
Saw	40 – 60	0,02 – 0,1
Mill	30 – 50	0,3 – 0,5
Drill	0,5 – 2,0	0,1 – 0,6

Table 4

Calculation of cutting speed

$$v_c = D \cdot \pi \cdot n / 60$$

v_c – cutting speed

D – tool diameter [m]

n – tool rotational speed [min⁻¹]

Calculation of feed speed

$$v_f = f_z \cdot n \cdot z / 1000$$

v_f – feed rate [m/min]

f_z – tooth feed

n – tool rotational speed [min⁻¹]

z – number of teeth

Cutting material

Tools with hard blades (e.g. HW-Leitz) can be used. In order to extend tool life, the use of DP-tipped tools (DP polycrystalline diamond) is recommended.

General advice

If chip removal is not carried out regularly, this can quickly lead to damage of the blade. As a result the required engine power is increased and the tool life will be shortened. If the shavings are too small they will then scrape and eventually blunt the tool, therefore leading to a short tool life.

Tooth forms

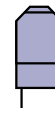

Fig. 11

TR/TR (Trapezoid tooth/ Trapezoid tooth)

Preferred tooth forms for the cutting of hard abrasive laminates.

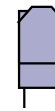

Fig. 12

FZ/TR (Flat tooth /Trapezoid tooth)

Tooth form for the processing of laminates and Compact Interior.



Fig. 13

WZ/FA (variable tooth with be- vel)

An alternative to FZ/TR tooth



Fig. 14

HZ/DZ (Pendulum tooth/ Concave tooth)

Tooth forms for excellent and below on machines without scoring units



Fig. 15

HZ/FA (Concave tooth with bevel)

Similar use to HZ/DZ only with longer machine life without scoring units.

For single cuts, it is imperative that the vibration of the panels is prevented using used panels.

Stack height is in compliance with machine capacity.

Cutting

Vertical panel splitting, table and sliding table saws without scoring unit

For circular saw blades with a positive rake angle and saw shaft under the work piece. Due to the positive rake angle, the cutting pressure takes effect using the stable table support.

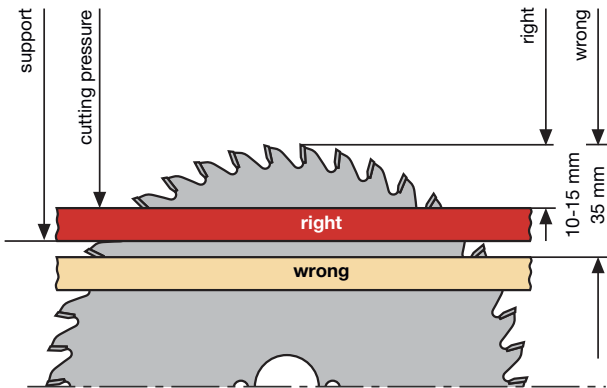

Fig. 16

For circular saw blades with a negative rake angle and saw shaft above the work piece. Through the negative rake angle, the cutting pressure takes effect using the stable table support.

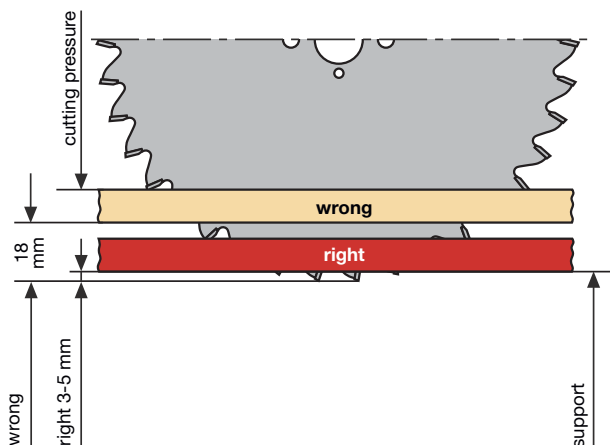

Fig. 17

Adjustment

- Visible side upwards;
- very narrow saw guide;
- smooth alignment of the FunderMax Compact Interior panels on the workbench with the saw blade;
- correct blade protrusion.

Depending on the blade protrusion, the entrance and exit angles and therefore the quality of the cutting edges will change. If the upper cutting edges are unclear, the saw blade will need to be adjusted to a higher level. The saw blade must be adjusted to a lower level for an unclear cut of the underside. This is how the best height adjustment is determined.

Sliding table saws and panel splitting machines with scoring unit and pressure beams.

Scoring circular saw blade:

In order to achieve a good cutting edge quality on the saw exit side, the use of a scoring unit is recommended. The cutting width of the scoring circular saw blade is slightly bigger than that of the main circular saw blade so that the exiting teeth of the main saw no longer touch the cutting edge. As a secure and smooth circulation of the work pieces can only be guaranteed using a pressure device, divided scoring circular saw blades are used on the table and sliding table machines.

Panel splitting unit with scoring aggregate and pressure device.

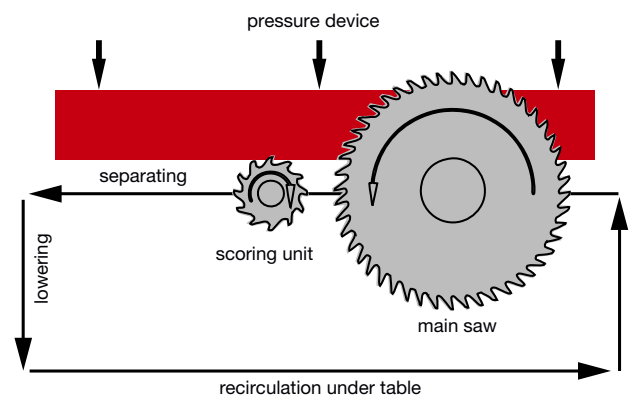

Fig. 18

Operating diagram of the conical scoring circular saw. For the maintenance of tools (always step-by-step), the cutting widths must be aligned with one another.

Cutting width of main saw blade = cutting width rate of the scoring saw

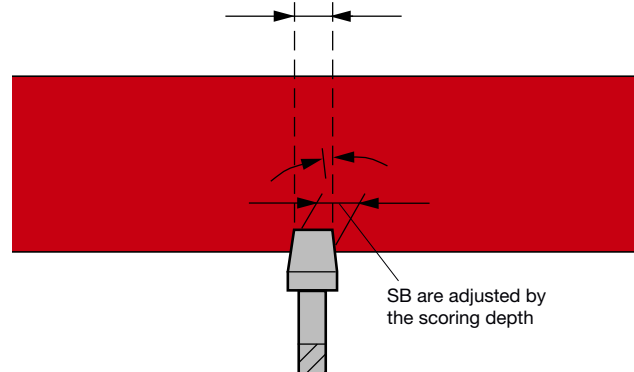

Fig. 19

Processing Recommendations

Cutting with handheld tools

■ Finely toothed handheld saws are suitable for single cuts. Low set teeth are preferable. The sawing should be done from the panel surface area, where the saw is at an angle of approximately 30° relative to the surface area.

■ For straight cuts with handheld circular saws, a stop bar or guide rail should be used. Saw blades suitable for hard metal use should be used. The sawing takes place from the panel underside using the following tooth forms: Variable tooth for coarse cuttings, flat tooth/trapezoid tooth for clean cuts of FunderMax Compact Interior panels and panels which are bonded on both sides.

Milling machines – edge processing

■ Edge processing by hand: For the finishing of edges, files are suitable. The file direction moves from the decorative side to the core. For broken edges, fine files, plane files, sand paper (100-150 grain) or scrapers can successfully be used.

■ Edge processing with handheld machines: to mill bevels electric hand planes with bevel or bevel grooves can be used. Hand routers are used along with hard metal tools for special tasks (e.g. wash basin recess, Trax-coupling etc.). In order to protect the FunderMax Compact Interior panel surface areas, the supporting surface of the hand routers should be covered with for e.g. panel parts, no felt! Milling shavings should be carefully removed.

Milling cutter diameter	10-25 mm
Cutting speed v_c	30-50 m/sec.

We recommend hard metal tipped milling cutters, which are also available with indexable inserts. For a better functioning of your tools, height-adjustable milling cutters are preferable. The sharp edges will be broken down afterwards.

■ The processing of edges with stationary machines: For milling work on the FunderMax Compact Interior panels, the optimal ratio of teeth, cutting speed and feed rate should be observed. If the shavings are too small, the machine will scrape (burn) and therefore blunt quickly, meaning it only has a short service life. On the other hand, if the shavings are too big, the edges will be wavy (strokes) with an unclean finish. High rotational speeds are not the only criterion for good quality edges! When working with the hand fed machines, only those with the marking 'MAN' or 'BG-Test' should be used. Furthermore, the given machine speed range should neither be exceeded nor fallen short of for reasons of safety. Hand fed machines should only be used when working in the opposite direction.

Milled edges can be finished in the following way: Sand the edge surface and smooth out the sharp edges with sandpaper. When processing edges, hand planes with steel residue can be used. It is also recommended that HSS blades are used. The cutting angle of the blade should be approx. 15°.

For the processing of FunderMax Compact Interior panels, milling heads with an HW indexable insert blade or diamond-tipped cutter are suitable.

Joining

To join in climb or conventional (e.g. variable milling)

The following machines are used:

Spindle moulding machine, edge processing machines and Double-end profiler (hand fed in conventional motion only)

Information on milling equipment:

Milling head with reversible blades, divided cuts and reciprocal shaft angle for a splinter-free joining edge. Machine creates cylindrical finish for large material thickness (approx. 0.10 mm). For completely straight cutting surface, the Diamaster joint cutter WF 499-2 is recommended.

You will find detailed information at company Leitz (Supplier advice on page 19)



Leitz joint milling head-indexable insert model

Fig. 20

For soundproof joints on narrow work piece surfaces climb and conventional (variable milling)

The following machines are used:

Edge processing machines, copy milling machines etc.

Information on milling equipment:

Composite tool with mutual shaft angle for a splinter-free joining edge and straight narrow surface. Noise reduction up to 5dBA and highly efficient collection of shavings (over 95%).



Leitz Diamaster joint cutter DP-tipped

Fig. 21

Processing Recommendations

Routers

For processing using router machines and machining centres, solid hard metal twist or diamond-tipped router drills are best suited. Work pieces must be well clamped and if necessary, additional mechanical tensioners can be used to support the suction cup. It is also recommended that shrink-fit ThermoGrip jaw chucks are used instead of collect chucks as they offer the highest stability and stiffness of all known tensioning systems for shaft tools.

A satisfactory processing result can only be achieved if there is sufficient stiffness in the machine.

'Light' radial machines are only of limited suitability. Ideal: Stiff portal machines

Format, groove and finish milling

For high requirements of cut quality - Z3 model for high feed rates.

The following machines are used:

Router machines with/without CNC control, machining centres, special milling machines with milling spindles for use with shaft work tools.

Information on milling equipment:

Marathon laminate for enhanced service life and reduced gradient for the formation of built-up edges. Usually used for roughing end mills, cutting allowances of approx. 1-2mm mirror grinding on the rake surface for processing.



Leitz Spiral router machine marathon finish

Fig. 22

Router cutters for formatting, and grooving with ledge free cut

The following machines are used:

Router machines with CNC control, machining centres, special milling machines with milling spindles for use with shaft work tools.

Information on milling equipment:

Negative rake angle of the blade for chip-free finish when grooving and for support of the work piece tensioning for small mill parts. Can be re-sharpened 5 to 8 times with normal blunting. Short, stable cutting blade therefore particularly suited for grooves and shaping of abrasive and hard-to-cut materials.



Leitz router machine Diamaster PLUS

Fig. 23

Edges and Grooves

Grooved edges on FunderMax Compact panels should always be bevelled, not sharp-edged! This spares the corners of the machine (indexable inserts) and prevents a notch effect. The service life can often decrease dramatically depending on the height adjustment, the machine type and form, the cutting requirements and support material. For high volume production, the use of diamond-tipped machines should be considered.

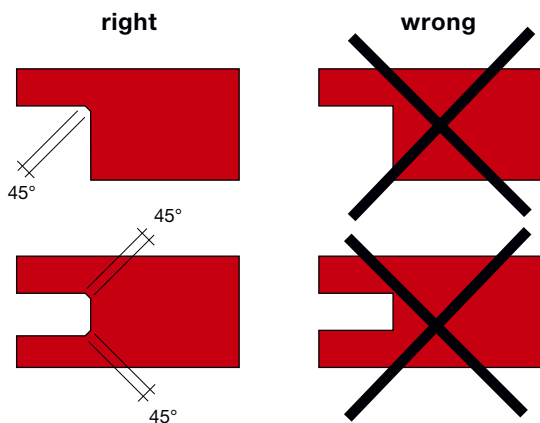

Fig. 24

Edge sanding

With standard machines, grain 100 to 120. Edges can also be grinded using sand paper or a scraper. A matte colour finish of the black panel edges can be achieved if combined with silicone-free oil.



Fig. 25

Inner notches and cut-outs

With inner notches and milling grooves, the corners are consistently rounded off. The inner radius should be kept as large as possible (minimum radius 5 mm). For inner notches and milling grooves over 250 mm side-length, the radius must be gradually increased in line with the side-length. Inner notches can be directly formed using the milling cutter or they can be pre-drilled with a corresponding radius, before the cut from drill hole to drill hole is milled. Sharp-edged corners are weak and lead to the formation of cracks due to tension. Moreover, all edges must be ripple-free. If, sharp-edged corners are required for constructive reasons, this can only be achieved through a combination of Compact panel blanks. The suitable cutting, milling and drilling machines for the production of inner notches and milling grooves are described in the previous sections.



Milling groove in the FunderMax Compact Panel

Fig. 26

Machine suppliers

Leitz GmbH & Co. KG
 Leitzstraße 80
 A-4752 Riedau
 Tel.: +43 (0)7764/8200 – 0
 Fax: +43 (0)7764/8200 – 111
 E-Mail: office.riedau@rie.leitz.org
 www.leitz.org

OERTLI-LEUCO Werkzeuge GmbH
 Industriepark Runa
 A-6800 Feldkirch
 Tel.: +43 (0)5522/75787-0
 Fax: +43 (0)5522/75787-3
 E-Mail: info@oertli.at
 www.oertli.at

Ledermann GmbH & Co. KG
 Willi-Ledermann-Straße 1
 D-72160 Horb am Neckar
 Tel.: +49 (0)7451/93 – 0
 Fax: +49 (0)7451/93 – 270
 E-Mail: info@leuco.com
 www.leuco.com

Processing recommendations

Variants of edges and corners

For Max Compact Interior panels and Max Compact-forming elements, no edge protection is necessary.
For visible edges, there are a wide variety of structural possibilities.

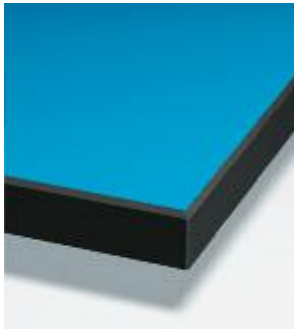

Standard bevel Fig. 27a

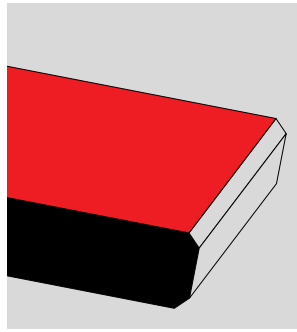

Standard bevel Fig. 27b

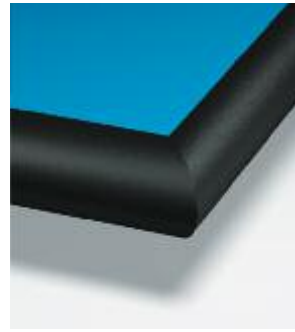

Milling contour 3 Fig. 31a

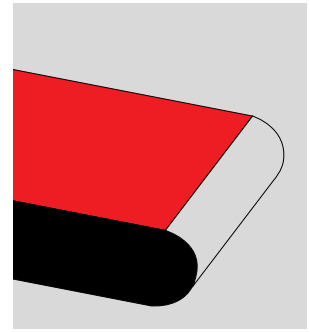

Milling contour 3 Fig. 31b



Rounded edges on both sides Fig. 28a

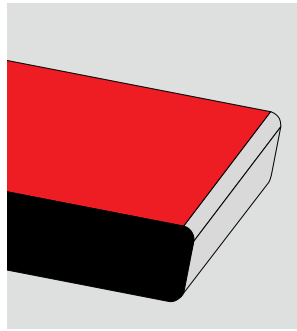

Rounded edges on both sides Fig. 28b

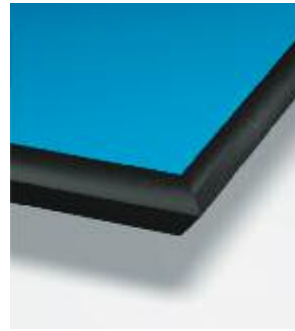

Milling contour 4 Fig. 32a

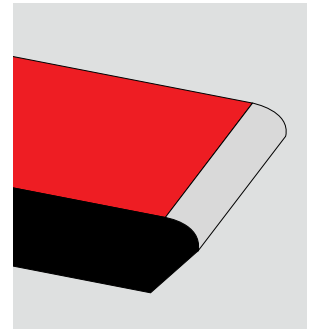

Milling contour 4 Fig. 32b



Milling contour 1 Fig. 29a

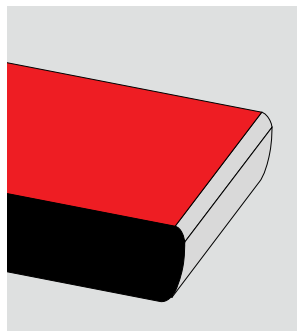

Milling contour 1 Fig. 29b

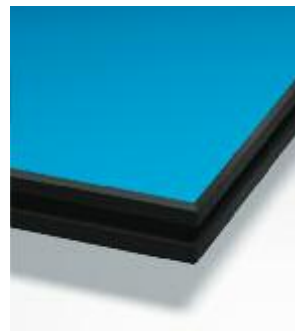

Standard bevel/groove Fig. 33a

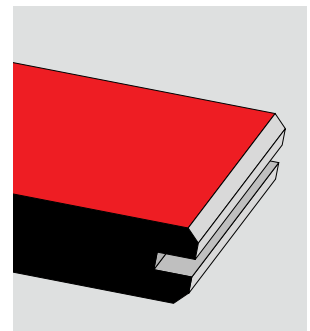

Standard bevel/groove Fig. 33b



Milling contour 2 Fig. 30a

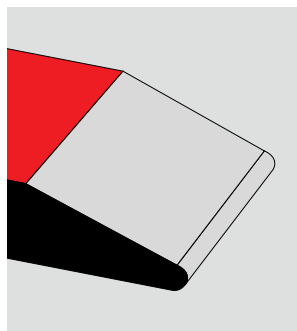

Milling contour 2 Fig. 30b

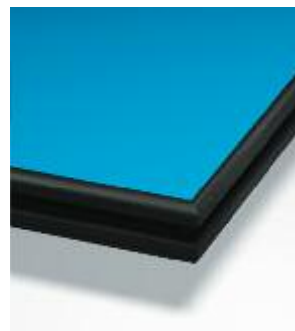

Rounded edges on both sides/groove Fig. 34a

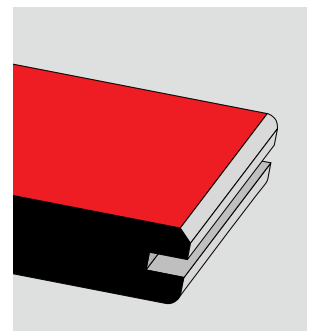

Rounded edges on both sides/groove Fig. 34b

The current data sheet on processing possibilities can be found at: 'www.fundermax.at' under 'Downloads' – 'ordering facilities'.

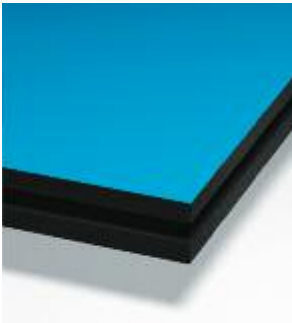

Milling groove Fig. 35a

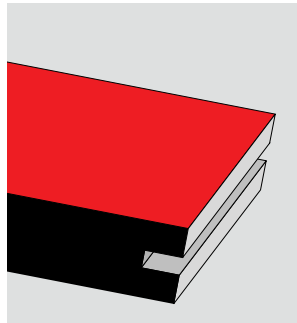

Milling groove Fig. 35b

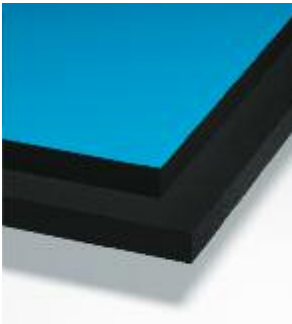

Milling notch Fig. 36a

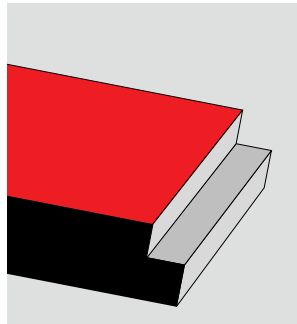

Milling notch Fig. 36b

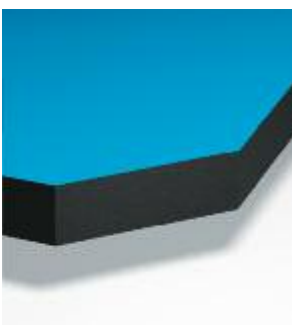

Bevelled corner Fig. 37a

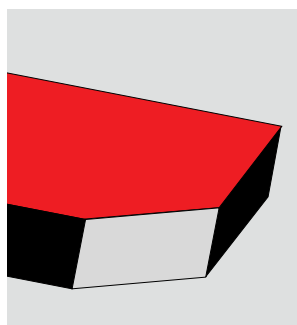

Bevelled corner Fig. 37b

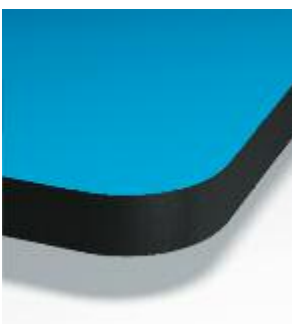

Rounded corner Fig. 38a

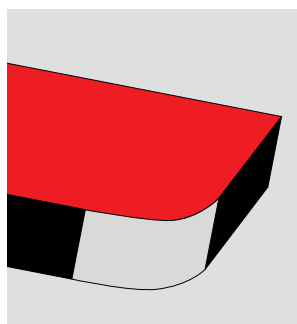

Rounded corner Fig. 38b

Processing recommendations

Drilling

Solid hard metal twist or dowel drills are used for drilling. In machining centres, the use of the main spindle instead of the drilling beams for a rpm of 2000 – 4000 min⁻¹ and a feed rate of 1.5 – 3 m/min, is recommended. The exit speed of the drill must be carefully selected so that the melamine surfaces of the Compact Interior panels are not damaged. Shortly before the drill exits the work piece in full diameter, the feed rate must be reduced by 50%. When drilling through-holes, the counter-pressure should be built up using hardwood or equivalent material to prevent break-offs of the melamine surface.



Fig. 41

For the screwing of blind holes perpendicular to the panel levels, please ensure:

- Tap drill diameter (D) = screw diameter minus approx. 1 screw channel depth.
- Drilling depth (a) = Panel thickness minus 1-1.5 mm
- Screw-in depth = Drilling depth minus 1 mm

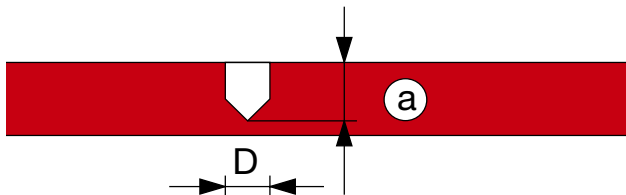

Fig. 39

For screw fittings parallel to the panel level, please ensure:

- The residual thickness (b) of the Compact Interior panel must be at least 3 mm.
- The hole diameter of the drillings parallel to the panel surface must be selected in such a way to avoid any splitting of the compact panels when tightening the screws.
- For screw fittings parallel to the panel surface, metal sheet and chip board screws are suitable.
- In order to ensure respective stability, a minimum depth of engagement of 25 mm is necessary.
- Screw fittings parallel to the panel levels are to be avoided with Compact forming elements. It is imperative that tests to establish the correct drill diameter are carried out.



Fig. 40

For the drilling of Compact Interior Panels, drills for plastics are best suited. This means twist drills with a point angle of $\leq 90^\circ$. They have a large gradient and chip space. The sharp drill bits mean that these drills are also very suitable for the drilling of through-holes as they cut cleanly through the underside of the material.

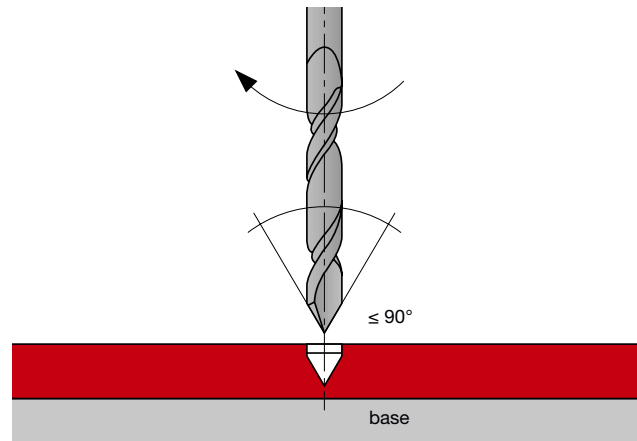

Fig. 42

Universal drilling of blind and through-holes.

The following machines are used:

Point-to-Point drilling machines, through feed drilling machines, CNC machining centres, box column drill, inlet-fitting drilling machine, drilling units, hand drills.

Information on the drills:

Flat roof drill bits. Shaft diameter identical to blade diameter. Adaptable for shaft-D 10 mm with reducing bush TB 110-0 or PM 320-0-25.



Leitz-drill HW-solid, Z2

Fig. 43

Tiered hinge drilling

Particularly for screw-in hinges in door manufacturing.

The following machines are used:

CNC machining centres, drilling units, hand drills.

Information on the drill:

Model HW Z 2, 2-tiered. 1tier with roof drill bit.



Leitz-drill shaft 10 mm

Fig. 44

Drilling of blind holes

In particular dowel holes in cabinetry. Particularly suitable for the tear-free drilling of blind holes in visible quality as well as the processing of panel materials. Not suitable for through-holes!

The following machines are used:

Point-to-Point drilling machines, through feed drilling machines, inlet fitting drilling machines, drilling units, CNC machining centres.

Information on the drill:

Roughing geometry with extremely clean cut. Model HW-solid with highly wear-resistant HW varieties. High stability and long service life. Polished chip space for minimal friction and feed force.



Leitz-drill shaft 10 mm

Fig. 45

Pre-punching ensures better control for hand drilling.

Diamond-tipped drills are not suitable for Compact panels.

Processing recommendations

Basics

Screws should never come into contact with the edges of the drillhole. They must have clearance on all sides so that the material can adapt to temperature and moisture fluctuations. In this way, the formation of cracks around the holes as well as panel warping, is avoided.

If raised countersunk-head screws are used, underlay rosettes are necessary.

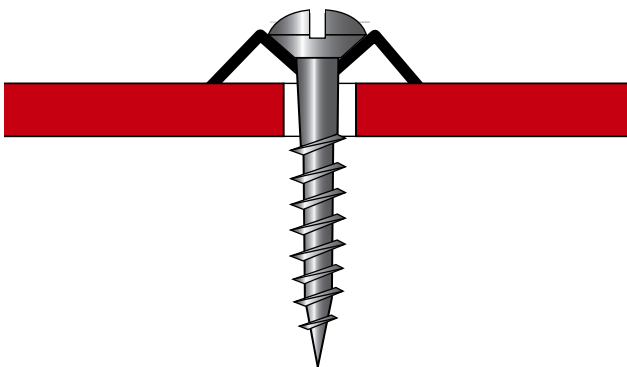

cheese-head screw with underlay rosettes

Fig. 46

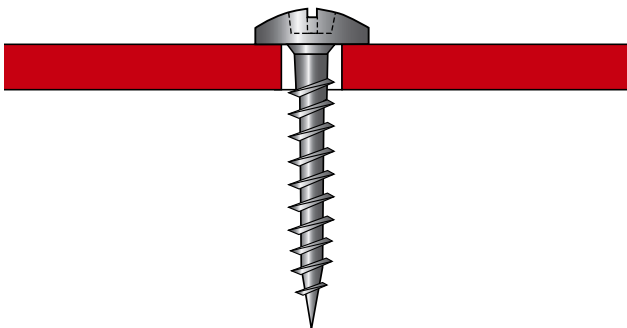

round-head screw covering slide points

Fig. 47

Attention to V-joints an expansion clearance on plat fragmentations!

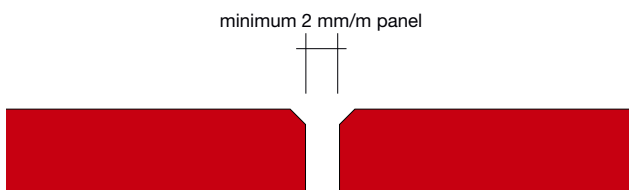

V-joints with expansion clearance

Fig. 48

Bonded edge joints

In order to increase the adhesive surface, special bevel sections can be milled (Leitz) or, joints with groove or external springs (ideally compact strips) can be produced.

During the adhesive process, it must be ensured that both bonded panels are joined in the same running direction (see construction information page 41).

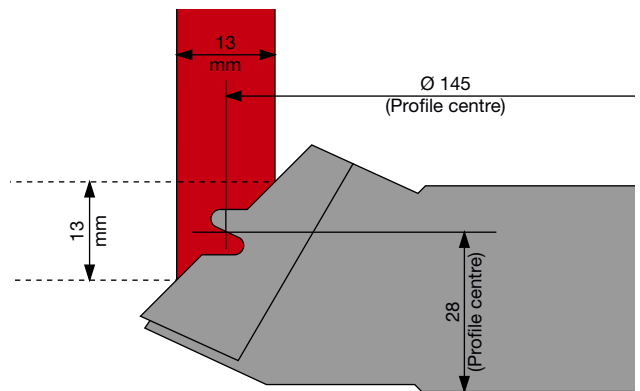

Leitz profile cutter head Pro 610-1-5

Fig. 49

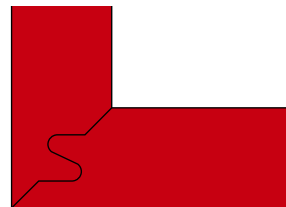

Corner joint with Leitz profile cutter

Fig. 50

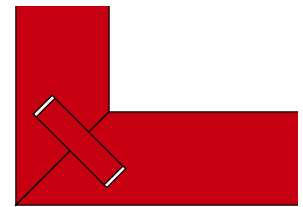

Corner joint with grooves and external springs

Fig. 51

For the gluing of FunderMax Compact Interior panels, reactive adhesives such as epoxy or solvent-free PU glue are suitable (in order to find the best suitable adhesive, it is recommended that you consult the adhesive manufacturer).

Be careful when using PU-adhesives. These adhesives foam and the surface area of the compact panel must be cleaned before the adhesive hardens. Otherwise, a mechanical cleaning is necessary, and can lead to damage of the FunderMax Compact Interior surfaces.

Gluing

Adhesive joints should be carried out in such a way that dimensional changes of the FunderMax Compact Interior panels and Max Compact forming parts are allowed. The panels must only be bonded in the same running direction and conditioning, otherwise tensions may occur (tip: identify decorative design before cutting). FunderMax Compact Interior panels have twice as much shrinkage and swelling room breadthwise than lengthwise. If adhesive joints are put under frequent pressure, they should be supported using mechanical joints.

Adhesive surfaces should be both sanded, dust-free and pre-treated (see processing guidelines of the adhesive manufacturer).

Depending on the given application, the following adhesive types are recommended by the manufacturer:

The gluing of FunderMax Compact one below the other

■ Stiff adhesive joints: reactive adhesives such as polyurethane and epoxy glue. Beware that hardened glue residue can not be removed without damaging the surface of the FunderMax Compact Interior panels. Dispersion adhesives (white glue) and condensation adhesives (PVA glues) are not suitable.

■ Elastic adhesive joints: Adhesions using PUR Kitten e.g.: Würth 'glues and seals', Sikaflex 252, Teroson-Terostat 92, Dinitrol 600, Dinitrol 605, Dinitrol F500, Dinitrol 410 UV Plus, from Fuller ICEMA 101/25 + curing agent 7etc. have been tested.

The gluing of FunderMax Compact Interior with insulants

Solvent-free reactive adhesives with polyurethane or epoxy resin adhesive e.g.: ICEMA RR145/44 or ICEMA R145/12, silicon adhesive 100 from Ramsauer.

Gluing of FunderMax Compact Interior with wood

After sanding the Compact panels, they can be bonded to wood materials using high-quality PVAc glues (white glue). A condition being that the material can absorb the glue moisture during the setting process.

Gluing of FunderMax Compact Interior to metal

The different thermal expansion behaviour of both materials in fluctuations of temperature and air moisture, must be considered. For thin panel materials of 1 mm to 3 mm thickness, the adhesion must take place across the entire surface and also using elastically binding adhesives. The thinner the panels used the

greater the risk of tearing of existing tensions. In particular, if there are recesses which have not been appropriately finished, that is, they have not been drilled with smooth edges. Furthermore, poor application of the adhesive on different places or notches on the panel corners, could be an exit point for tears. An important parameter for the functioning adhesion of FunderMax Compact Interior panels to metal supports is the adhesive joint thickness. This should be between 0.5 mm und 1 mm for the total adhesion. High-quality contact adhesives for e.g. solvent-free based adhesives, which combine elastics and chemicals (not through the release of water) are suitable for hardening. It must be noted that metal components are largely not as flat as for e.g. calibrated wood materials. This makes the maximum surface contact between adhesives, Compact panels and metal supports more difficult. Adhesive errors could emerge as a result which could in turn lead to tears. Careful rolling with small hand rollers is recommended! The pressing of entire panels is only possible using entirely flat materials

Summary

Large panel thickness means that the adhesion of metal materials poses little risk. The use of 1 mm thick laminate panels requires even more care when processing as there is a risk of residue. All other conditions for an appropriate processing must be adhered to such as the conditioning of the FunderMax Compact panels to the intended climatic conditions on site and the preparation of metal surfaces in accordance with the glue manufacturer guidelines etc.

Mounting adhesives for the support of mechanical joints

For the support of mechanical joints, cyanoacrylate adhesives (superglue), as well as hot-melt adhesives are used.

■ Elastic adhesive systems - Adhesive joints with PUR Kitten e.g.: Würth 'glues and seals' Sikaflex 252, Teroson-Terostat 92, Dinitrol 600, Dinitrol 605, Dinitrol F500, Dinitrol 410 UV Plus, etc. have also been tested for the installation of basins in Max Compact forming elements.

For ventilated wall-cladding on corresponding sub-structures, elastic adhesive systems and acrylate adhesive tapes are suitable.

E.g. from 3M: VHB adhesive tape systems Acrylic foam 4950 1 mm thick or 4912F 2 mm thick.

When using double-sided adhesive tapes, it is particularly important to consider the climatic conditions at the place of intended use, as dimensional changes of the supports or Compact panels can lead to uncontrollable tensions.

Processing recommendations

The greater the surface area and thus possible length variation, the thicker the adhesive tape must be.

Panels which have a thickness of 4 mm or more, are fixed using an adhesive bead.

For the distances of these vertical tracks to each other, the following applies:

Panel thickness 4 mm	max. 100 mm
5 mm	max. 200 mm
6 mm	max. 300 mm

The initial tack is made using a double-sided adhesive tape which also regulates the adhesive joints to 3 mm after pressing.

In any case, sample tests should be carried out before working. Please follow the recommendations of the glue manufacturer under all circumstances.

There are adhesives on the market, which show good bonding strength and resistance against temperatures and moisture. These are therefore well suited for the adhesion of FunderMax Compact Interior panels.

Adhesives

Dispersion adhesives

E.g. PVAc-glues = white glues

Condensation resin adhesives

E.g. urea, resorcin and phenolic resin

Contact adhesives

E.g. Polychloroprene adhesives

Reaction adhesives

E.g. Epoxide, unsaturated polyester, Polyurethane adhesives

Hot-melt adhesives

For joint adhesion, EVA-based, polyamide or Polyurethane.

For adhesive suitability please see the following table

	Dispersion adhesives (e.g. PVAc-glue)	Condensation resin adhesives (e.g. urea-, resorcin-, phenolic resin adhesives)	Contact adhesives (e.g. polychloroprene-, nitrile rubber adhesives)	Reactive adhesives (e.g. epoxy-resin, polyurethane adhesives)	hotmelt adhesive for edging strips (e.g. EVA, polyamide, PUR)
Wood supports	●	●	●	●	●
Paper honeycomb	●	●	●	●	●
Paper honeycomb foam or honeycomb from					
Polystyrene			●1)	●1)	
Phenol		●	●	●	
Polyurethane		●	●	●	
Aluminium				●	
Metal supports	Please keep to information provided by the glue manufacturer!				
Aluminium panels	Please keep to information provided by the glue manufacturer!				
Steel panels			●	elastic solvent-free PUR adhesives	
Mineral supports: Mineral, glass or foam: supports. Gypsum and calcium silicate panels	Please keep to information provided by the glue manufacturer!				

1) Does not include elements that corrode polystyrene.

Table 5

Adhesion process

■ Both the FunderMax Compact Interior panels, as well as the materials bonded to them, must be thoroughly cleaned before adhesion. They must be free from dust, grease, oils and moisture or particles that could mark the surface area after adhesion. During the adhesive process, the ambient atmosphere should be 18 - 25°C and 50 - 65 % relative air moisture.

■ The adhesive joint quality must be selected in relation to the adhesive material quality of the support material and its intended use.

Use of adhesive joints in accordance with DIN 68602:

B1, B2 for normal to high air moisture conditions of adhesions in interior fittings.

B3, B4 for normal to extremely wet conditions both indoor and outdoor.

A high water-resistance of the adhesive joints does not increase the water-resistance of the support material!

■ The information provided by the given glue manufacturer should be consulted. It is recommended that test adhesions are carried out under similar room conditions. When working with adhesives, solvents and hardeners, safety guidelines must be followed for reasons of occupational safety.

Pressing temperature

■ Tension-free composite elements are most safely produced in pressing temperatures of 20°C, that is, room temperature. Higher temperatures mean a reduction in setting time. However, as dimensional changes are also dependent on the temperature, and as the temperature of FunderMax Compact Interior could vary from other materials, 60°C should not be exceeded in order to avoid heightened tensions which could lead to the warping of the materials.

■ If special adhesions require higher pressing temperatures, the following temperature/time combinations should not be exceeded in order to avoid deformations:

Temperature	Time
60°C	5 min.
70°C	4.5 min.
80°C	4 min.
90°C	2 min.
100°C	1 min.

Processing recommendations

Adhesive application and pressing process

The adhesive application must be equally distributed across the surface area. It must be ensured that the applied quantity is the same on both sides of the support material in order to avoid distortions. This particularly applies to water-based adhesive systems. Therefore, when using these systems, the applied quantity of adhesive must be kept at an optimal level.

Dispersion adhesives

■ PVAc glues, two-component PVAc-glues

The adhesive application can be done either by hand using a notched trowel or hand roller, or using an adhesive application machine.

Cold pressing:

screw clamps, spindle presses, multi-daylight presses.

Warm pressing:

Multi-daylight presses, short-cycles presses, double volume presses.

■ Always ensure: optimal and even adhesive application as well as the compliance with pressing temperatures and times.

Pressing pressure 2-4 bar.

Condensation resin adhesives

■ Melamine urea-based resin

urea-based resorcinol resin

For the elastification of the adhesive joints, the adhesive approaches require the following additions (e.g. type powder). These also lead to a clean-lined surface. Different types of curing agent allow for a wide variety of adhesion and pressing data.

■ Warning: Impurities on the FunderMax Compact surfaces as a result of adhesive or curing agent residue, must be removed before the pressing, otherwise they can no longer be removed without damaging the surface. Separating agents prevent an adhesion of adhesive residue on FunderMax Compact surfaces and press plates. Resorcinol resin adhesives are used for the production of elements with a high flame resistance.

Cold pressing: screw clamps, spindle presses, multi-daylight presses.

■ Warm pressing: multi-platen presses, short-cycle presses, double volume presses.

■ Always observe: optimal and even adhesive application as well as compliance of the pressing temperatures and times. Pressing pressure 2 - 4 bar.

Contact adhesives (solvent-based)

■ When working with solvent-based contact adhesives, occupational safety and accident prevention regulations must be adhered to! Contact adhesives demand particular care when handling. Therefore, the guidelines laid out by the glue manufacturer must be followed precisely. Adhesive application by hand: with brush, notched trowel; by machine using spray systems (hot and cold) or using casting devices on FunderMax Compact panels and support materials. When applying the adhesive using the notched trowel, the direction of application on the supports and Compact panels should be at a right angle to one another.

■ It is important to ensure that there are good drying conditions (Finger test!), no draft, no dust! Contact adhesives require a short but powerful pressing pressure in order to ensure a secure adhesion.

■ Pressing with hand rollers, rolling presses, multi-daylight presses.

■ Contact adhesives with curing agents; these adhesives lead to a higher tolerance and temperature resistance of the adhesive joints.

■ Information on the particular processing conditions will be provided by the glue manufacturer.

Reactive adhesives

■ Used for special adhesions. However, the large number of different types means that there are no standard, valid processing recommendations. Beware of surface area damage as a result of the setting adhesives.

Hot-melt adhesives

■ Used for edge bonding in corresponding devices

Our application engineers are happy to answer any questions concerning the processing and finishing of FunderMax Compact.



Ceiling elements

Fig. 52

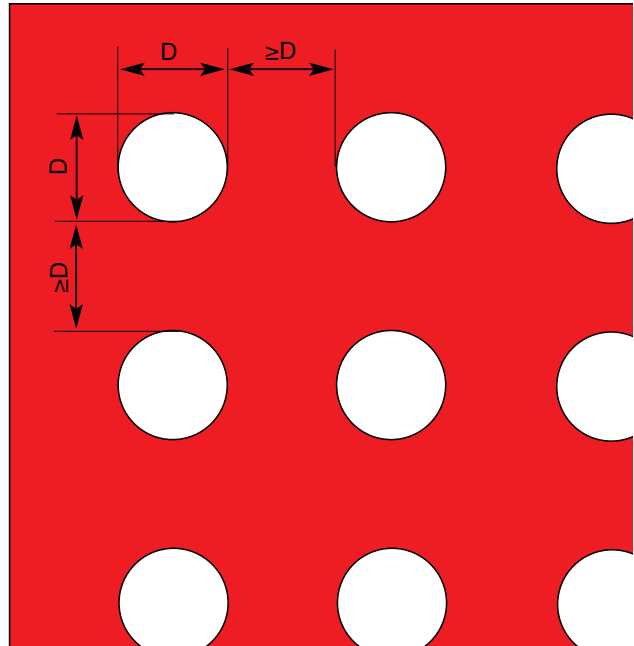

Minimum distances for hole patterns with fall protection

Fig. 53

Perforation of FunderMax Compact panels

FunderMax Compact Interior panels can be perforated using different shapes which are mostly in the form of holes or slits.

Notes on the use of railings:

- The thickness of the panels is directly linked to the fastening distances.
- The fastening must fulfill static requirements as well as building regulations. However, the fastening distances must be reduced to at least 20% for holed panels.
- Holes and slits are not supposed to be used as a climbing aid for children. Holes should not be any bigger than 50 mm in diameter.
- For recesses in FunderMax Compact Interior, we recommend using the corresponding fall protection by Max Alucompact42 panels. For railings see page 84.

Hole patterns

- (The panels are weakened by the recesses). It is recommended that Max Alucompact42 panels be used. (Beware! Sizes for Max Alucompact42: 2140 x 1060 mm, 2800 x 1300 mm und 4100 x 1300 mm)
- Never remove more than 20% of the material if intended for fall protection.
- The space between the holes or slits must be at least as wide as the diameter of the holes or slits. This also applies to the edge distances.



Staircase railing-enlarged holes in Max Alucompact42

Fig. 54

Chemical resistance

FunderMax Compact Interior panels

The focus of this recommendation is a depiction of the chemical resistance of the FunderMax Compact panels and the resulting possibilities for application.

Besides their excellent mechanical values, the melamine resin and hygienic pore-free sealed surfaces of the FunderMax Compact Interior panels mean a high temperature resistance, easy cleaning and a good resistance to chemicals. The stain resistance requirements in accordance with EN 438 are also met.

They can therefore be used when for example;

- Lab and technical chemicals
- Solvents
- Disinfectants
- Dyes (certain types)
- Cosmetics

are used on the surface.

Particular attention must be paid to the careful processing of FunderMax Compact Interior panels, as certain requirements may be imposed due to the particular field of use when constructing certain laboratory and medical facilities. For this kind of application we recommend the use of Max Resistance (lab panels).

FunderMax Compact Interior panels are resistant against many different chemicals. However, several chemicals may still corrode the surface.

Therefore, of crucial importance are:

- The concentration
- Exposure time
- The temperature of substances used

The following lists, although there is no guarantee that they are complete, give an overview of the resistance of FunderMax Compact Interior panels (at room temperature) against the effects of frequently occurring or used substances (solid, dissolved, fluid, gaseous).

When using substances that are not listed, we ask that you enquire further and recommend own sample tests.

No damage

FunderMax Compact Interior panels are resistant against the following substances and agents.

These elements do not have an impact on the surface area of FunderMax Compact Interior panels, even after prolonged exposure (16 hours).

Substance	chemical formula
Acetic Acid	CH ₃ COOH
Acetone	CH ₃ COCH ₃
Active charcoal	
Alcohol	ROH
Alcohol, beverages	
Alcohol, primary	RCH ₂ OH
secondary	RR'CHOH
tertiary	RR'R''COH
Aldehyde	RCHO
Alum liquor	KAl(SO ₄) ₂ ·12H ₂ O
Aluminium chloride	AlCl ₃ .aq.
Aluminium sulphate	Al ₂ (SO ₄) ₃
Aluminium potassium sulphate	KAl(SO ₄) ₂
Amides	
Amines, primary	RCONH ₂
secondary	RNH ₂
tertiary	(RR')NH
Ammonia	(RR'R'')N
Ammonium chloride	NH ₄ Cl
Ammonium sulphate	NH ₄ Cl
Ammonium sulphate	(NH ₄) ₂ SO ₄
Amyl acetate	NH ₄ SCN
Amyl alcohol	CH ₃ COOC ₅ H ₁₁
Aniline	C ₆ H ₅ OH
Animal fat	C ₈ H ₅ NH ₂
Animal fodder	
Arabinose	
Ascorbic acid	C ₆ H ₈ O ₅
Asparagine	C ₆ H ₈ O ₆
Aspartic acid	C ₄ H ₇ O ₃ N ₂
p-Aminoacetophenon	C ₈ H ₉ O ₂ N
Baker's yeast	NH ₂ ·C ₆ H ₄ ·COCH ₃
Barium chloride	
Barium sulphate	BaCl ₂
Benzaldehyde	BaSO ₄
Benzene	C ₆ H ₆ CHO
Benzidine	C ₆ H ₆
Benzoic acid	NH ₂ ·C ₆ H ₄ ·C ₆ H ₄ NH ₂
Biogel	C ₆ H ₅ COOH
Blood	
Boric acid	
Butylacetate	H ₃ BO ₃
Butyl alcohol	CH ₃ COOC ₄ H ₉
Cadmium acetate	C ₄ H ₇ OH
Cadmium sulphate	Cd(CH ₃ COO) ₂
Caffeine	CdSO ₄
Calcium carbonate (lime)	
Calcium chloride	CaCO ₃
Calcium hydroxide	CaCl ₂
Calcium nitrate	Ca(OH) ₂
Cane sugar	Ca(NO ₃) ₂
Carbolic acid	C ₁₂ H ₂₂ O ₁₁
Carbolic acid - xylene	C ₆ H ₅ O ₄
Carbon tetrachloride	C ₆ H ₅ OH·C ₆ H ₄ (CH ₃) ₂
Casein	CCl ₄
Castor oil	
Cedarwood oil (concentrated)	
Cement	
Chloral hydrate	
Chlorobenzene	CCl ₃ CH(OH) ₂
Chloroform	C ₆ H ₅ Cl
Cholesterol	CHCl ₃
Citric acid	C ₂₇ H ₄₅ OH
Clay	C ₆ H ₅ O ₇
Coal	

Substance	chemical formula
Cocaine	C ₁₇ H ₂₁ O ₄ N
Coffee	
Common salt	NaCl
Copper sulphate	CuSO ₄ .aq
Cosmetics	
Cresol	CH ₃ C ₆ H ₄ OH
Cresylic acid	CH ₃ C ₆ H ₄ COOH
Cyclohexane	C ₆ H ₁₂
Cyclohexanol	C ₆ H ₁₁ OH
Detergents	
Dextrose	C ₆ H ₁₂ O ₆
Digitonin	C ₅₅ H ₉₂ O ₂₉
Dimethyl formamide	HCON(CH ₃) ₂
Dimethyl acetic acid	CH ₃ COOH
Dioxan	C ₄ H ₈ O ₂
Dulcitol	C ₆ H ₁₄ O ₆
Ester	RCOOR'
Ethanol	C ₂ H ₅ OH
Ether	ROR'
Ethyl acetate	CH ₃ COOC ₂ H ₅
Ethylene dichloride	CH ₂ :CCI
Fodder	
Foodstuffs	
Formaldehyde	HCOH
Formic acid up to 10%	HCOOH
Fructose	C ₆ H ₁₂ O ₆
Galactose	C ₆ H ₁₂ O ₆
Gelatine	
Glacial acetic acid	CH ₃ COOH
Glucose	C ₆ H ₁₂ O ₆
Glycerine	CH ₂ OH·CHOH·CH ₂ OH
Glycocoll	NH ₂ CH ₂ COOH
Glycol	HOCH ₂ ·CH ₂ OH
Graphite	C
Greases	
Gypsum	CaSO ₄ ·2H ₂ O
Heparin	
Heptanol	C ₇ H ₁₅ OH
Hexane	C ₆ H ₁₄
Hexanol	C ₆ H ₁₃ OH
Hydrogen peroxide 3%	H ₂ O ₂
Hypophysin	
Imido "Roche"	
Immersion oil	
Ink	
Inorganic salts and their mixtures	
Inositol	C ₆ H ₆ (OH) ₆
Insecticides	
Isoamyl acetate	CH ₃ COOC ₅ H ₁₁
Isopropanol	C ₃ H ₇ OH
Ketone	RC:OR'
Lactic acid	CH ₃ CHOHCOOH
Lactose	C ₁₂ H ₂₂ O ₁₁
Lead acetate	Pb(CH ₃ COO) ₂
Lead nitrate	Pb(NO ₃) ₂
Laevoluse	C ₆ H ₁₂ O ₆
Lipstick	
Lithium carbonate	Li ₂ CO ₃

Table 6a

Chemical resistance

No damage

FunderMax Compact Interior panels are resistant against the following substances and agents.

These substances do not have an impact on the surface area of FunderMax Compact Interior panels, even after prolonged exposure (16 hours).

Substance	chemical formula
Magnesium carbonate	MgCO ₃
Magnesium chloride	MgCl ₂
Magnesium sulphate	MgSO ₄
Maltose	C ₁₂ H ₂₂ O ₁₁
Manitol	C ₆ H ₁₄ O ₆
Mannose	C ₆ H ₁₂ O ₆
Mercury	Hg
Mesoinositol	C ₆ H ₈ (OH) ₆
Methanol	CH ₃ OH
Milk	
Mineral oils	
Mineral salts	
Nail varnish	
Nail varnish remover	
α-Naphtol	C ₁₀ H ₇ O ₇
α-Naphtylamine	C ₁₀ H ₇ NH ₂
Nickel sulphate	NiSO ₄
Nicotine	C ₁₀ H ₁₄ N ₂
p-Nitrophenol	C ₆ H ₄ NO ₂ OH
Nonne-Appelt-reagent	
Octanol	C ₈ H ₁₇ OH
n-Octyl alcohol	C ₈ H ₁₇ OH
Olive oil	
Oleic acid	CH ₃ (CH ₂) ₇ CH:CH(CH ₂) ₇ COOH
Organic solvents	
Ointments	
Pandy's reagent	
Paraffin waxes	C _n H _{2n+2}
Paraffinic oil	
Pentanol	C ₅ H ₁₁ OH
Peptone	
Petroleum benzin	
Phenol and phenol derivatives	C ₆ H ₅ OH
Phenolphthalein	C ₂₀ H ₁₄ O ₄
Polishing agents (creams/waxes)	
Potash lye up to approx. 10%.	KOH
Potassium bromate	KBrO ₃
Potassium bromide	KBr
Potassium carbonate	K ₂ CO ₃
Potassium chloride	KCl
Potassium hexacyanoferrate	K ₄ Fe(CN) ₆
Potassium iodate	KJO ₃
Potassium nitrate	KNO ₃
Potassium sodium tartrate	KNaC ₄ H ₄ O ₆
Potassium sulphate	K ₂ SO ₄
Potassium tartrate	K ₂ C ₄ H ₄ O ₆
Potato starch	
Propanol	C ₃ H ₇ OH
1,2-Propylene glycol	CH ₃ CHOHCH ₂ OH
Pyridine	C ₅ H ₅ N
Qinol	HOC ₆ H ₄ OH
Raffinose	C ₁₈ H ₃₂ O ₁₅ ·5H ₂ O
Rhamnose	C ₆ H ₁₂ O ₅ ·H ₂ O
Rochelle salt	
Saccharose	= Cane sugar
Salicylaldehyde	C ₆ H ₅ OH·CHO
Salicylic acid	C ₆ H ₅ OHCOOH
Saponon	
Seawater	
Soap	

Substance	chemical formula
Sodium acetate	CH ₃ COONa
Sodium carbonate	Na ₂ CO ₃
Sodium chloride	NaCl
Sodium citrate	Na ₃ C ₆ H ₅ O ₇ ·5H ₂ O
Sodium diethylene barbiturate	NaC ₈ H ₁₁ N ₂ O ₃
Sodium hydrogen sulphite	NaHSO ₃
Sodium hydrogencarbonate (Sodium carbonate)	NaHCO ₃
Sodium hydroxide solution (up to approx. 10%)	NaOH
Sodium hyposulphite	Na ₂ S ₂ O ₄
Sodium nitrate	NaNO ₃
Sodium phosphate	Na ₃ PO ₄
Sodium silicate	Na ₂ SiO ₃
Sodium sulphate	Na ₂ SO ₄
Sodium sulphide	Na ₂ S
Sodium sulphite	Na ₂ SO ₃
Sodium tartrate	Na ₂ C ₄ H ₄ O ₆
Soil	
Soot	
Sorbitol	C ₆ H ₁₄ O ₆
Standard acetate solution	
Standard I + II -Nutrient agar	
Standard I + II -Nutrient broth	
Starch	
Starch -common salt solution	
Stearic acid	C ₁₇ H ₃₅ COOH
Styrene	C ₆ H ₅ ·CH:CH ₂
Sugar and sugar derivates	
Sulphur	S
Talcum powder	3MgO,4SiO ₂ , H ₂ O
Tannic acid	C ₇₆ H ₅₂ O ₄₈
Tartaric acid	C ₄ H ₆ O ₆
Tea	
Test serum for blood grouping	
Tetrahydrofuran	C ₄ H ₈ O
Tetraline	C ₁₀ H ₁₂
Thiourea	NH ₂ CSNH ₂
Toepfer's reagent	
Toulene	C ₆ H ₅ CH ₃
Trehalose	C ₁₂ H ₂₂ O ₁₁
Tricholoro ethylene	CHCl:CCl ₂
Trypsin	
Tryptophane	C ₁₁ H ₁₂ O ₂ N ₂
Turpentine	
Tymol	C ₁₀ H ₁₄ O
Tymol buffer solution	
Urea solution	CO(NH ₂) ₂
Urease	
Uric acid	C ₅ H ₄ N ₄ O ₃
Urine	
Vanillin	C ₈ H ₈ O ₃
Vaseline	
Water	H ₂ O
Water colours	
Xylene	C ₆ H ₄ (CH ₃) ₂
Yeasts	
Zinc chloride	ZnCl ₂
Zinc sulphate	ZnSO ₄

Table 6b

No damage under short exposure

Surfaces from FunderMax Compact Interior panels remain unchanged when the following substances are spilled on them (particularly in liquid or dissolved form) or if they are in contact for a short amount of time. That means the panels are washed with a wet towel within 10-15 minutes and then rubbed dry. Please note that the time of exposure is an important factor in the extent of corrosion on the HPL surfaces, even with diluted agents. As a result of the evaporation of the diluted material, the concentration of the substance increases over a period of time and the surfaces of FunderMax Compact Interior panels will be corroded, even though the concentration used will mostly be below those named in the following list. Focused sample tests are recommended.

Substance	chemical formula
Amino-S acid up to 10%	NH ₂ SO ₃ H
Aniline dyes	
Antifilm agents	
Arsenic acid up to 10%	H ₃ AsO ₄
Boric acid	H ₃ BO ₃
Crystal violet (Gentian violet)	C ₂₄ H ₂₈ N ₃ Cl
Esbach's reagent	
Formic acid over 10%	HCOOH
Fuchsin solution	C ₁₉ H ₁₉ N ₃ O
Hair dyes and bleaches	
Hydrochloric acid up to 10%	HCl
Hydrogen peroxide over 3-30% (Perhydro)	H ₂ O ₂
Inorganic acids up to 10%	
Iodine solution	I
Iron (II) chloride solution	FeCl ₂
Iron (III) chloride	FeCl ₃
Mercury (II) chromate	HgCr ₂ O ₇
Methylene blue	C ₁₆ H ₁₈ N ₃ ClS
Millon's reagent	OHg ₂ NH ₂ Cl
Nitric acid up to 10%	HNO ₃
Nylander's reagent	
Oxalic acid	COOH.COOH
Phosphoric acid up to 10%	HPO ₄
Picric acid	C ₆ H ₂ OH(NO ₂) ₃
Potash lye over 10%	KOH
Potassium hydrogensulphate	KHSO ₄
Potassium chromate	K ₂ CrO ₄
Potassium dichromate	K ₂ Cr ₂ O ₇
Potassium iodide	KJ
Potassium permanganate	KMnO ₄
Silver nitrate	AgNO ₃
Sodium hydrogen-sulphate	NaHSO ₄
Sodium hydroxide sol. over 10%	NaOH
Sodium hypochlorite	NaOCl
Sodium thiosulphate	Na ₂ S ₂ O ₃
Sublimate solution (= mercury (II) chloride)	HgCl ₂
Sulphuric acid up to 10%	H ₂ SO ₄
Sulphurous acid up to 10%	H ₂ SO ₃
Varnishes and adhesives, (chemically curing)	

Table 7

High damage risk

The following chemicals destroy the FunderMax Compact Interior panel surfaces and must be removed immediately, as they could also leave behind dull spots and coarseness.

Substance	chemical formula
In concentrations greater than 10%:	NH ₂ SO ₃ H
Amino sulpho acid	
Inorganic acids such as	
Arsenic acid	H ₃ AsO ₄
Aqua regia	HNO ₃ + HCl = 1:3
Chromosulphuric acid	K ₂ Cr ₂ O ₇ + H ₂ SO ₄
Hydrochloric acid	HCl
Hydrofluoric acid	HF
Hydrogen bromide	HBr
Nitric acid	HNO ₃
Phosphoric acid	H ₃ PO ₄
Sulphuric acid	H ₂ SO ₄

Table 8

Aggressive gases

Frequent exposure to the following aggressive gases and vapours can lead to changes in the FunderMax Compact Interior panel surfaces:

Substance	chemical formula
Acid vapours	
Bromine	Br ₂
Chlorine	Cl ₂
Nitrose fumes	NxOy
Sulphur dioxide	SO ₂

Table 9

Chemical resistance

Max Compact Interior Plus

Sterilisability

Thanks to their excellent surface area, Max Compact Interior Plus panels are easy to clean and just as easy to sterilise as for e.g. stainless steel or OP tiles.

24-h-chemical resistance test

decor-independent	
Substance	Concentration
All solvents	
Nitric acid	10 %
Phosphoric acid	10 %
Acetic acid	10 %
Hydrogen peroxide	30 %
Sodium hypochlorite	13 %
Caustic soda	25 %
Ammonia	25 %

Table 10

Max Resistance (Lab panels)

With Max Resistance you get tested resistance. Authenticated and award-winning from ofi, the Austrian research Institute for Chemistry and Technology.

24-h-resistance test against disinfection materials

Assessment/Classification*)			
Substance	Concentration	White	Pastel Grey
Ethanol	70%	5	5
Formalin	5%	5	5
p-Chloro-m-cresol	0,3%	5	5
Chloramine T	5%	5	5
Alkyl-DMB-AC-BC	0,1%	5	5

Table 11

The surface area of Max Resistance panels remains unchanged after treatment from these standard disinfectants.

24-h-solvent resistance test

Assessment/Classification*)		
Substance	White	Pastel Grey
Acetone	5	5
Ethanol	5	5
n-Butyl acetate	5	5
Toluene	5	5
Trichlorethylene	5	5
Hexan	5	5
THF	5	5

Table 12

Max Resistance is completely resistant towards ketones, alcohol, esters, aromatic compounds, chlorinated hydrocarbons and aliphatic hydrocarbons and ethers.

24-h-disinfecting capability test

	E. Coli DSM 787		St. Aureus DSM 346	
	Resistance	OP-tiles	Resistance	OP-tiles
Initial values	5,0	4,9	4,9	4,9
Ethanol 70%	5,0	4,9	4,9	4,9
Formalin 5%	5,0	4,9	4,9	4,9
p-Chloro-m-cresol 0,3%	5,0	4,9	4,9	4,9
Tosylchloramid 5%	5,0	4,9	4,9	4,9
B.A.C. (Alkyl-Dimethylbenzylammoniumchloride) 0,1%	5,0	4,9	4,9	4,9
Buraton	5,0	4,9	4,9	4,9
Betaisodona	5,0	4,9	4,9	4,9

Table 13

Max Resistance demonstrates full sterilisability for all disinfectants against E.Coli DSM 787 and St.Aureus DSM 346.

log¹⁰-value of the KBE/ml

24-h-chemical resistance test

Substance	Concentration	Assessment/Classification*)	
		White	Pastel Grey
Hydrochloric acid	37%	5	5
Sulphuric acid	97%	5	5
Nitric acid	65%	2	2
Phosphoric acid	85%	5	5
Aqua regia		3	3
Acetic acid	98%	5	5
Caustic soda	20%	5	5
Silver nitrate	10%	3	3
Formic acid	98%	5	4
Potassium iodide	10%	4	4
Iodine	als Feststoff	3	3
Methyl red alk.	1%	5	5
Hydrofluoric acid	40%	5	3
H ₂ O ₂	30%	5	5
Chromosulphuric acid		5	5
KMnO ₄	10%	5	5
Iron(III)chloride	10%	4	4
Copper sulphate	10%	5	5
Sodium hypochlorite	13%	5	5

Table 14

Max Resistance demonstrates an excellent resistance against acids, alkalis, coloured and corrosive saline solutions and oxidised and bleaching substances.

Small variations in the assessment are possible between the different decors. Aside from the tested values, there can be no guarantee for the resistance of the surface areas against other chemicals, dyes, solvents and disinfectants, as well as combinations of different chemicals and their effects under certain conditions (e.g. high temperature, long period of exposure). Own experiments are, in this instance, recommended.

24-h-stain resistance test against dye substances

Substance	Concentration	Assessment/Classification*)	
		White	Pastel Grey
Acridin orange	1%	5	5
Magenta	1%	5	5
Carbol Magenta	1%	3	5
Malachite green oxalate	1%	5	5
Methyl blue	1%	4	4
Methyl violet 2B	1%	5	5
Wright dye	1%	5	5
Gentian violet	1%	5	5

Table 15

Max Resistance reacts upon contact with indicators, colour reagents and dyes in medicine without causing any surface damage.

* Scale of assessment:

Grade 5	No visible changes
Grade 4	slight change of gloss quality and/or colour, only visible from certain angles.
Grade 3	Moderate change of gloss quality and/or colour
Grade 2	Considerable change of gloss quality and/or colour
Grade 1	Surface area damage and/or blistering

Cleaning

Cleaning instruction Compact and High Pressure Laminates

Type of stain	Cleaning procedure
adhesives	C
bacteriological stains	D
blood	D
chalk	A
coal tar (cigarettes)	C
coffee	A
colored ballpoint pens	C
dispersions (PVAc)	C
dust	A
emulsions paints	C
excrement	D
fingerprints	A
fitting foam	E
floor polish	B
fruit juice	A
germs	D
grease fats	A
grease, oil	A, B, C
hybrid-glu	E
limescale	G
lipstick	C
marker	C
marking pen	C
mordant	C
paints	C
pencil	A
polyurethane foam	E
rust	G
sealants (like silicone)	F
shoe polish	C
soap residue	A
spray paint	C
stamping ink	C
synthetic resins	E
tea	A
two-component adhesive	E
two-component lacquer	E
urea-glu	E
urine	D
water marks	G
water-soluble adhesives	A
water-soluble dyes	A
wax crayon	C
wax polish	C
wax residue	C

Table 16

Please start the cleaning procedure for unknown stains with basic cleaning, cleaning procedure A to G in order to perform the desired success. To prevent streaking you have to perform a final cleaning.

Basic cleaning

Clean the surface just with pure hot water and use a soft sponge – (DO NOT use the abrasive "green" side of the sponge), use a soft cloth or a soft brush (e.g. nylon brush).

Cleaning procedure A

Same as basic cleaning, in addition use common household cleaners without abrasives e.g. dish detergent (Palmolive, Fairy), window cleaner (Ajax, Frosch).

Cleaning procedure B

Same as basic cleaning, but you may additionally use organic solvents (acetone, alcohol, turpentine, thinner). For persistent dirt pollution try to clean mechanically. **Caution:** avoid scratching, use plastic or wooden spatula.

Cleaning procedure C

If the contamination is not removable, you can use a solution of soft soap - water (1:3). Depending on the degree of pollution leave it on the surface for a couple of minutes. Subsequently do the final cleaning.

Cleaning procedure D

Same as basic cleaning, but you may additionally use commercially available disinfectants. Steam cleaning is possible. Take care of the supporting material (e.g. wood beams, wall paneling, insulation, ...), to avoid wetting.

Cleaning procedure E

Remove immediately! If necessary, perform cleaning procedure C and final cleaning procedure.

Cleaning procedure F

Rub off the surface with a soft cloth or a soft sponge dry. If contaminants cannot be removed, use silicone remover (e.g. Molto).

Cleaning procedure G

Following the initial cleaning, liquid cleaners can be used with polishing chalk (Cif, ATA). Do this procedure only occasionally! For persistent limescale acidic cleaning agents may be used (for example, 10% acetic acid or citric acid). Subsequently do the final cleaning.

Final cleaning

Detergents have to be removed with water completely to avoid streaking. Finally clean with hot water and rub off the surface with an absorbent cloth or paper towel (Kitchen roll).

When cleaning with solvent:

observe the accident prevention regulations!
Open windows! No open flame!

Wall cladding



Fig. 55

Compact Interior

FunderMax Compact Interior and Max Compact forming elements offer a wide variety of design possibilities for both fixed and removable wall, column and ceiling cladding. They have been used in hospitals, swimming pools, train stations, barracks, schools and other buildings.

On the following pages we will show you a range of wall cladding mounting and application possibilities for FunderMax Compact Interior panels.



Fig. 56



Fig. 57

Wall Cladding



Fig. 58

Ventilated wall cladding

Max Compact Interior with black core is the product of choice for classic ventilated wall cladding. The ventilation guarantees a control of temperature and moisture, particularly for existing building moisture in the walls or climatic variations in adjacent rooms.

An unequal climate in front of and behind the materials can lead to warping of the panels. Therefore, the panels have a substructure meaning that a circulation of air (ventilation minimum 20 mm) between the panels and the wall is guaranteed, from top to bottom. Joints between the panels can, if desired, be closed. The expansion room of the panels must not be prevented. It must be ensured that the air supply from below and the extracted air above the panels are free and that the resulting moisture variations will be balanced out by the circulation of air.

Max Compact panels are also available in F-Quality.

Non-ventilated wall cladding

If ventilation is not possible or if it is undesirable for hygienic reasons, it can be omitted using Max Alucompact06 or Max Alucompact42 due to the special construction of this product. A stable, sustainable lamellas substructure must always be constructed. For this application it's possible to use stripes of Compact with a thickness of ≥ 6 mm. As these wall cladding panels can be sealed on all sides, it is possible to produce a wall protection that meets hygienic requirements such as easy cleaning and maintenance.

In this way, wet rooms, as well as public buildings, clean rooms, laboratories and medical facilities for e.g. operating theaters including the adjacent sterile inlet and outlet channels as well as preparatory and sterile areas, hospital rooms and doctor offices, all become hygienic and germ-free zones.

Please contact our technical support department directly if you have requests for direct screwed wall claddings without rear ventilation.

Technical note on Alucompact06

Max Alucompact06 can be used as non-ventilated wall cladding in a wide range of areas under the highest hygienic conditions. The 0.06 mm aluminium layer that lies under the decor on both sides, works as a vapour barrier and helps to prevent warping of the panels in different climatic conditions. Critical cases are those whereby non-ventilated wall cladding is used on the cold room side of non-heated rooms, e.g. the inner walls of cold rooms. As well as existing brickwork with possible moisture residue that can rise from the ground, for example, in the ground floor and basement of old buildings. This must be considered during the planning process. In these instances, we recommend Max Alucompact42.

Max Alucompact06 and Max Alucompact42 panels are also available in F-Quality.

Construction information

- A fixing of wall cladding directly to the wall is not appropriate with the given materials. A substructure should always be provided.
- In general, during the construction and fixing process it must be ensured, that the material is not exposed to stagnated water. The panel material must consistently be able to dry.
- Due to the material characteristics, during the bonding of Max Compact panels to one another - edge adhesions or bevels - it must be ensured that all connecting components have been manufactured in the same running direction. That means that they can be joined length to length and breadth to breadth. Therefore, the machine direction must always be indicated on the remaining panels.
- For extremely wet conditions, e.g. shower cubicles or similar, the mechanical edge adhesion is indispensable, particularly when used with an elastic and water-resistant binding adhesive system.
- The substructure must be protected against corrosion and rotting.
- Joints or components relating to the panels must be structured in such a way that installations are easily accessible.
- All corners within reach must be bevelled to form v-joints.
- On drywalls, the screw connections of the substructure must be included within the metal substructure.
- For non-ventilated wall claddings: Moisture permeable walls in particularly damp brickwork (solid brickwork, ready-mixed concrete), Max Alucompact42 must be used instead of Max Alucompact06.

Product	Field of use	
	Ventilated wall cladding	Non ventilated wall cladding
Max Compact Standard quality	●	
Max Compact F-Quality	●	
Max Alucompact06 Standard quality		●
Max Alucompact06 F-Quality		●
Max Alucompact42 Standard quality		●1)
Max Alucompact42 F-Quality		●1)

1) The appearance of high levels of moisture is to be expected

Table 17

The same logically applies to the Max Compact forming elements. Due to the formable panel construction, due care must be taken for the selected use and processing. Please consult our application engineers. We reserve the right to make changes in line with technical progress.

Wall Cladding



Fig. 59

Fixing possibilities for wall cladding using FunderMax Compact.

There are different fastening possibilities for wall cladding using FunderMax Compact Interior panels.

FunderMax Compact Interior panels can be screwed into a wooden substructure or riveted onto an aluminium substructure. FunderMax Compact Interior panels can also be glued onto a substructure consisting of wood, aluminium or HPL strips. Furthermore it is possible to fix Compact panels with suspension rails from wood or aluminium.

Invisible mechanical fastening

If a visible fastening device is not desired, FunderMax Compact Interior panels can also be attached to the wall using different suspension rails. The sections that are attached to the FunderMax Compact Interior panels, can be fixed using blind fasteners, screws or spreads for example. Ideally screws or sleeves are used with metal threads. In both cases, the hole in the compact panel is for drilling a smaller thread.

It is important that the horizontal suspension rails are suspended in such a way that a vertical ventilation is possible.

Visible mechanical fastening

For the use of screws or rivets as fastening devices, the following points must be followed: The centre of the borehole in the substructure must correspond with the centre of the borehole in the FunderMax Compact panels. The mounting devices should be attached from the middle of the panel outwards. A slide point and a maximum of 1 fixed point must be used. Sufficient expansion room must be ensured. In general the joints on the panels should be 2 mm/metre.

Sliding points

Depending on the necessary expansion clearance, the drilling diameter for sliding points in the FunderMax Compact panels is bigger than the diameter of the mounting material: The shaft diameter of the fixing device plus at least 2 mm per meter of cladding material from the fixed-point outwards. The head of the fixing device must be big enough to allow the borehole to remain invisible in the FunderMax Compact panels. The fixing device must be arranged in such a way that the panels can move. Rivets are attached with rivet gauges. The defined distance allows a movement of the parts in the borehole (clearance 0.3 mm). Screws should not be fastened too tightly. Do not use counter-head sunk screws, use washers if necessary.

Fixed point

The fixed point allows for the equal distribution (halving) of swelling and shrinking movements. The drill diameter in the FunderMax Compact panels is just as big as the diameter of the mounting device.

Per panel, a fixed point is drilled as close to the middle as possible. All other fastening holes are drilled as slide points.

Edge spacings

The edge spacings must be maintained for reasons of stability and flatness. In order to allow for dimensional changes, the panel joints must have joints of at least 2 mm per metre of panel.

The stability of cladding is determined by the substructure and the thickness of the cladding material.

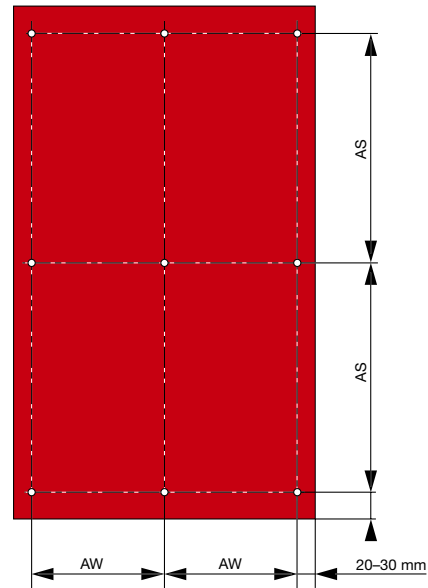

Fastening distances

Fig. 60

Maximum fastening distances		
Panel thickness	AS	AW
6 mm	600 mm	470 mm
8 mm	770 mm	620 mm
10 mm	920 mm	770 mm

Table 18

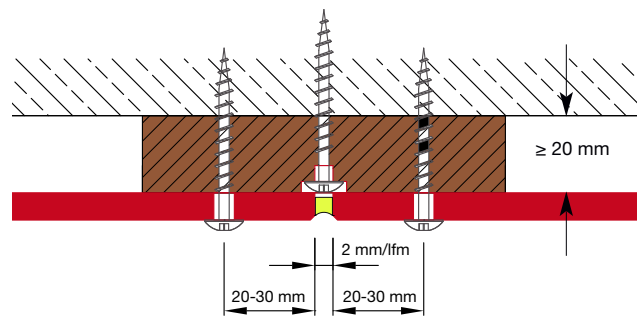

Variant with rear ventilation and Compact Interior panels

Fig. 61

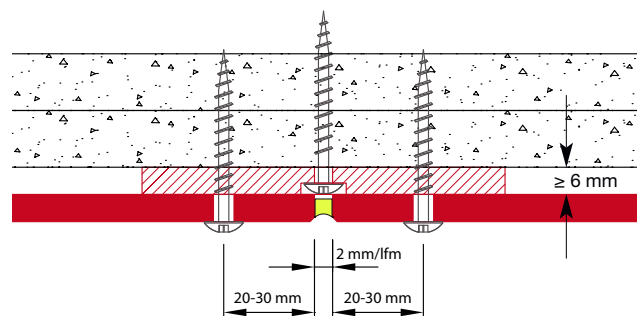

Variant without rear ventilation and with Alucompact06/42 panels

Fig. 62

Wall Cladding



Fig. 63

Glued fastening

An alternative to invisible, mechanical mounting is the adhesion of FunderMax Compact panels with specially developed adhesive systems.

As a substructure for adhesive wall claddings, vertically arranged strips made from wood, aluminium or Max Compact/ Max Alucompact06, are suitable.

For dry walls, a screw connection of the substructure strips to the metal substructure is necessary. For damp brickwork (solid brick work, ready-mixed concrete) a Max Alucompact42 must be used.

Edge spacings

The edge distances must be maintained for reasons of stability and flatness. In order to allow for dimensional changes, the panel joints must have joints of at least 2 mm per metre of panel.

For non-ventilated wall claddings, Max Alucompact06 can be used to seal the joints on all sides with a permanent elastic, hygienically sealed, low-maintenance silicone joint.

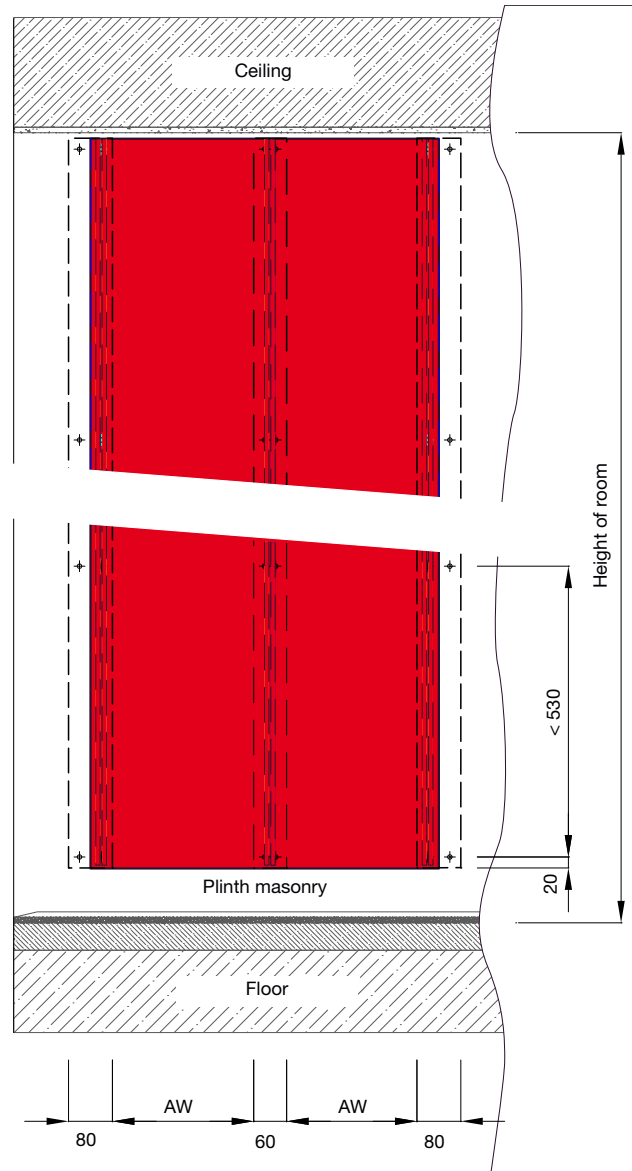

Frontal view of the substructure with bonded Max Compact panels

Fig. 64

Maximum_Fastening distance		
Panel thickness	vertical	AW
6 mm	< 530 mm	470 mm
8 mm	< 530 mm	620 mm
10 mm	< 530 mm	770 mm

Table 19

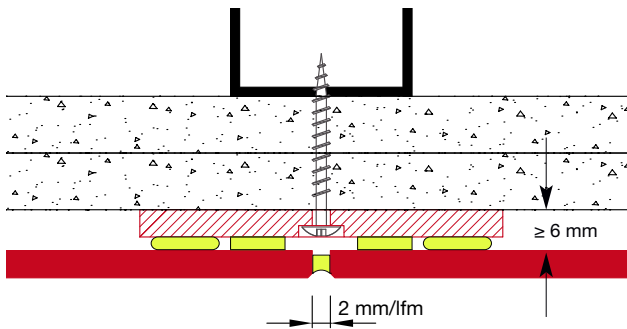

Variant without rear ventilation and with Alucompact06/42 panels Fig. 65

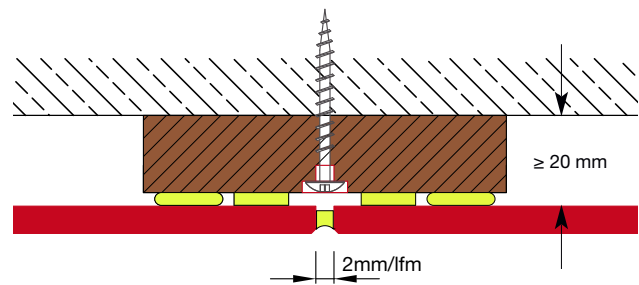

Variant with rear ventilation and Compact Interior panels Fig. 66

Pretreatment of aluminium substructures

- Sanding with abrasive fleece
- Pretreatment with cleaner
- Note airing time
- Apply primer thinly using a brush
- Observe (min./max.) drying time!

Pretreatment of wood substructures

- Planed wood with untreated surfaces without wood preservative.
- Apply primer thinly with a brush
- Observe (min./max.) drying time!

Pretreatment of FunderMax Compact panels

- Sanding with abrasive fleece
- Pretreatment with cleaner (chemical tissue)
- Observe drying time
- Apply primer thinly using a brush
- Observe (min./max.) drying times! All adhesive surfaces must clean, dry and grease-free

Gluing

- 3 mm mounting band laid out along the entire length of the vertical profiles (do not yet remove the protective film).
- Adhesive is applied as a triangle track (width 8 mm, height 10 mm) at 5 mm intervals from the profile edge and the mounting band.
- Panel mounting: remove the protective film from the mounting band. Panels are exactly aligned (mounting angle) press down until there is contact with the mounting band.

Basics

- Weather and dust protection is a necessary working condition (adhesive work must be carried out onsite).
- Air temperature must not be below 5° C, and must not exceed 35°C.
- Relative air moisture no greater than 75%.
- Temperature of the adhesive elements must be at least 3°C higher than the dew-point temperature of the air.
- Joints of the substructure profiles must not be bonded in an overlaid structure on the compact panels.
- The substructures must always be ordered vertically.
- The glue manufacturer regulations must be adhered to at all times.

Advice: Do not clean the decorative side (visible side) with the glue manufacturer 'cleaner'!

Wall Cladding



Fig. 67

Ventilated glued wall protection-flush to the wall

FunderMax Compact Interior Panels – flush to the wall, an adhesion of mounting aligned strips of Compact panels. Edging on all sides with edge formed angles made from stainless steel (approx. 1 mm thick). Wall cladding using FunderMax Compact Interior panels can be kept almost completely flush to plasterboard and door frames. The substructure varies depending on the wall material.

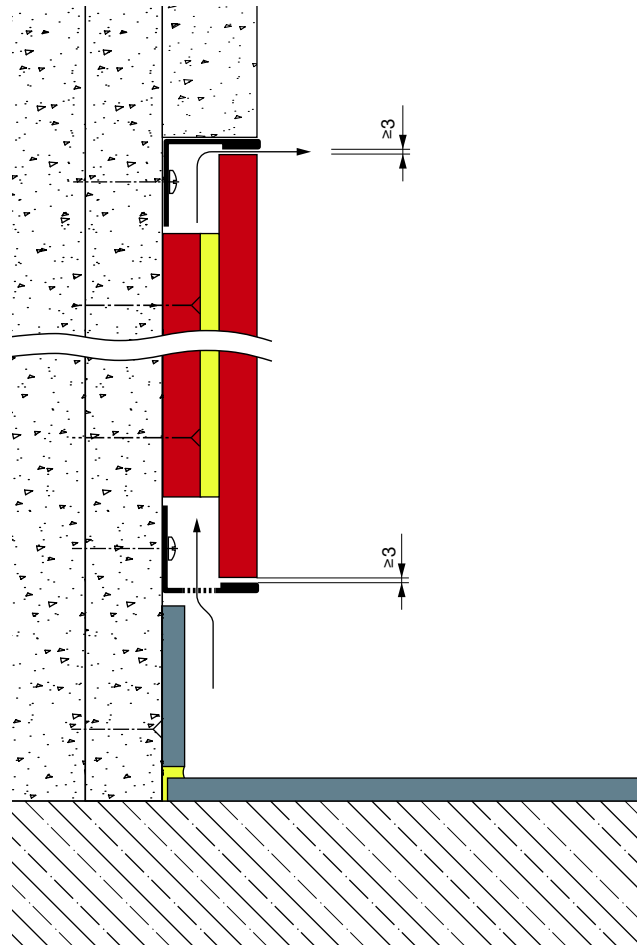

Vertical section

Fig. 68

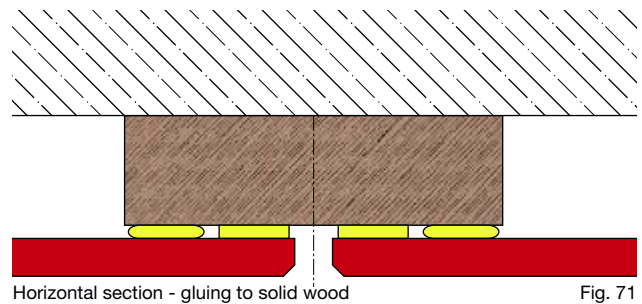

Fig. 69

Ventilated glued wall cladding

An secret, mechanical fastening of the FunderMax Compact Interior panels is possible with the adhesive system.

Specialised working instructions and training from the glue manufacturers is necessary.



Horizontal section - gluing to solid wood

Fig. 71

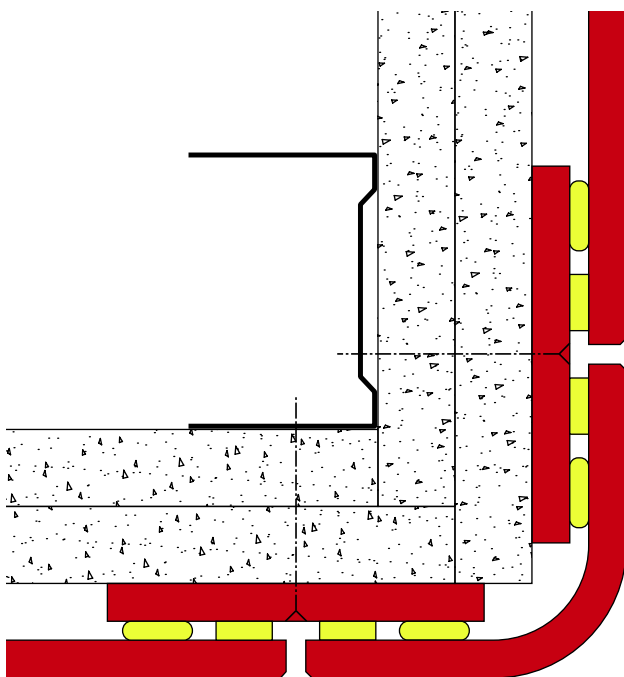

Horizontal section - gluing to the Compact panel strips

Fig. 70

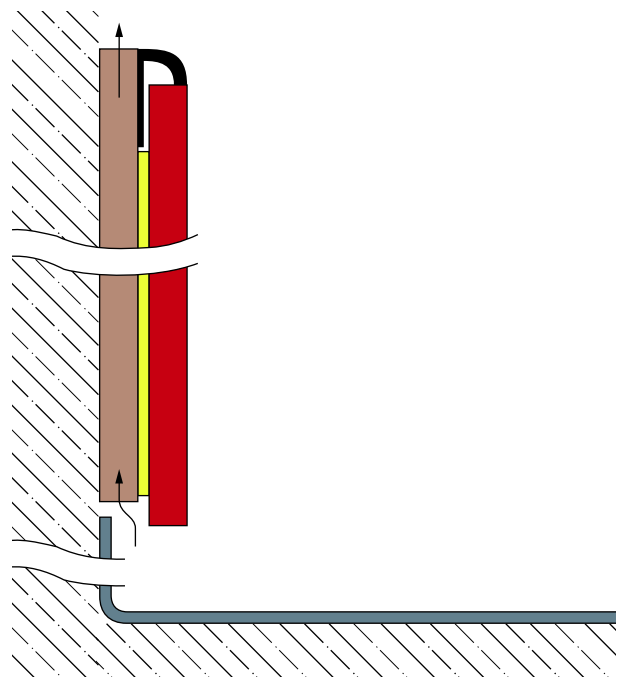

Vertical section - Gluing with end profile

Fig. 72

Wall Cladding



Fig. 73

Ventilated wall cladding and wall protection with grooved strips.

Horizontal, slotted laths mounted flush to the wall. The alternative possibility is a complete frame. The panels are hung using hinge blocks on the notches of the horizontal laths or the frame. The deep hinge, compared with the groove frame, gives a ventilation space of ≥ 5 mm. Joints are attached using strips behind the FunderMax Compact Interior panels.

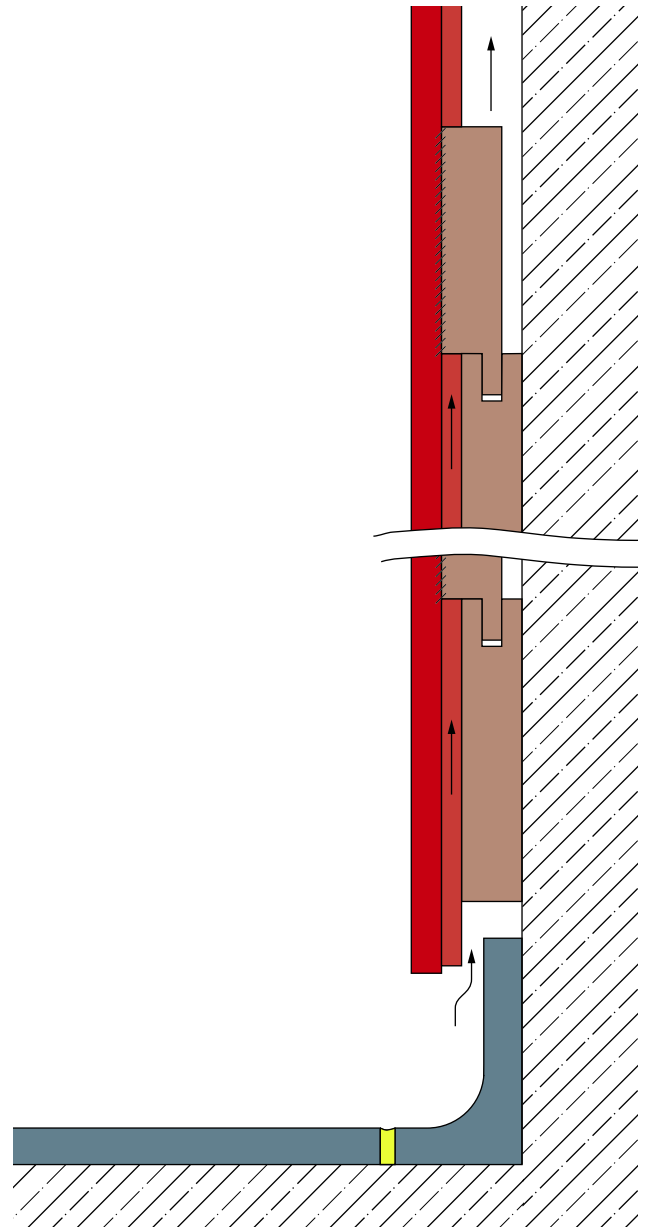

Perpendicular cut of the ventilated wall protection with grooved strips

Fig. 74

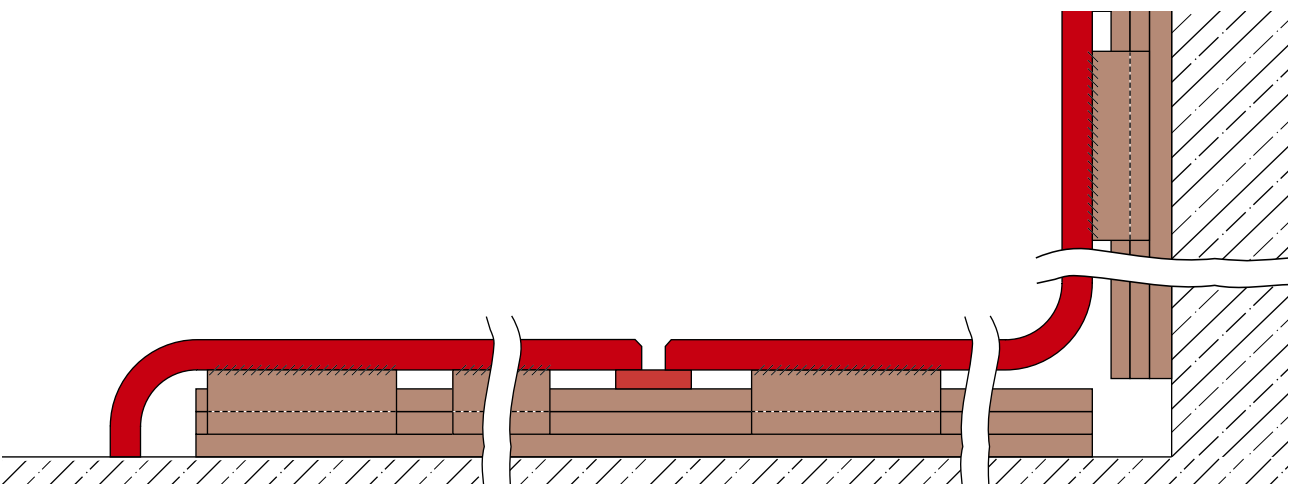

Horizontal cut of the ventilated wall protection with grooved strips

Fig. 75



Fig. 76

Ventilated wall cladding and corner protection

Corner protection elements from Max Compactforming Elements with integrated hinge blocks, are hung on corresponding counterparts.

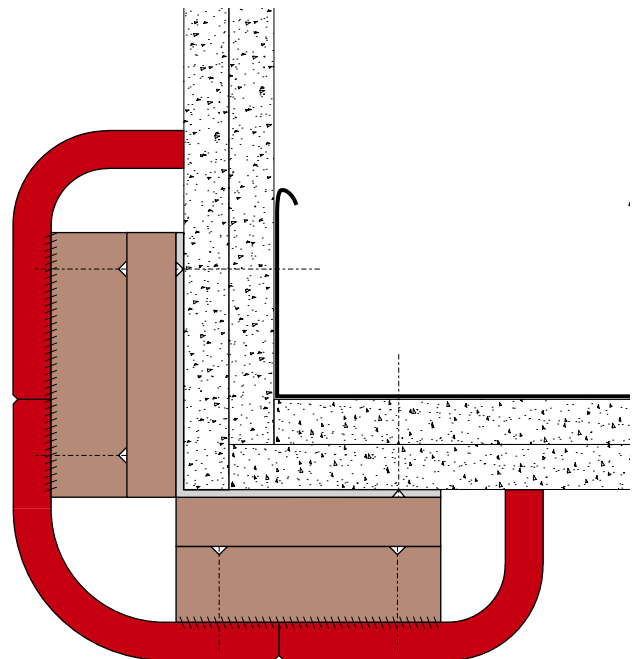

Horizontal section corner protection with Max Compactforming Fig. 77

Wall Cladding



Fig. 78

Ventilated wall protection

Wall protection for hospitals and the nursing sector. Consisting of Max Compactforming elements which are hung in grooved strip.

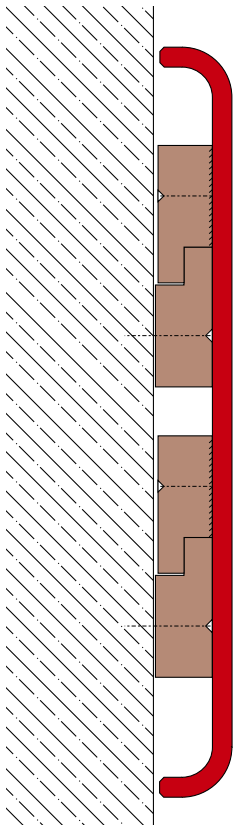

Fig. 79

Horizontal section wall protection with Max Compactforming U-elements and hanging rail

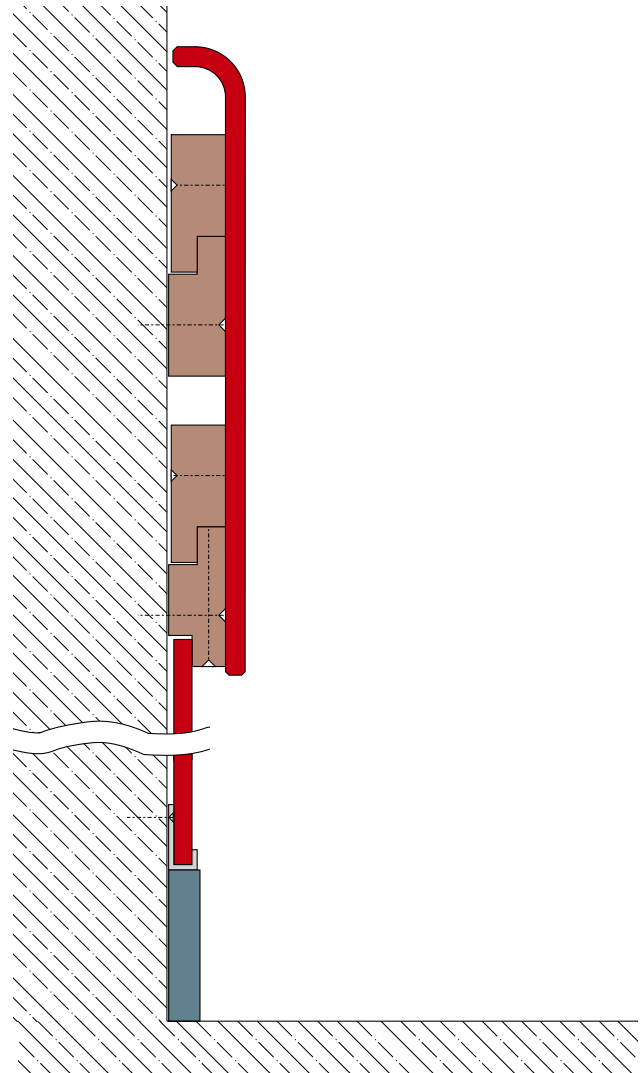

Fig. 80

Horizontal section wall protection with Max Compactforming L-parts and hanging rail



Fig. 81

Ventilated wall cladding and wall protection with Lohr wall protection profiles

Fastening strips are to be suspended or fastened in a sliding motion, in order to avoid a warping of the materials through variations of tension.

Max Compact panels (thickness ≥ 10 mm) are hung using aluminium suspended shackles in the flush mounted aluminium support frame - base and slope profile. The advantages include the low depth of construction and the simple removal.

This profile system is run by the company Helmut Lohr. You can find the address for this company on page 55 or on the download section of our Homepage www.fundermax.at

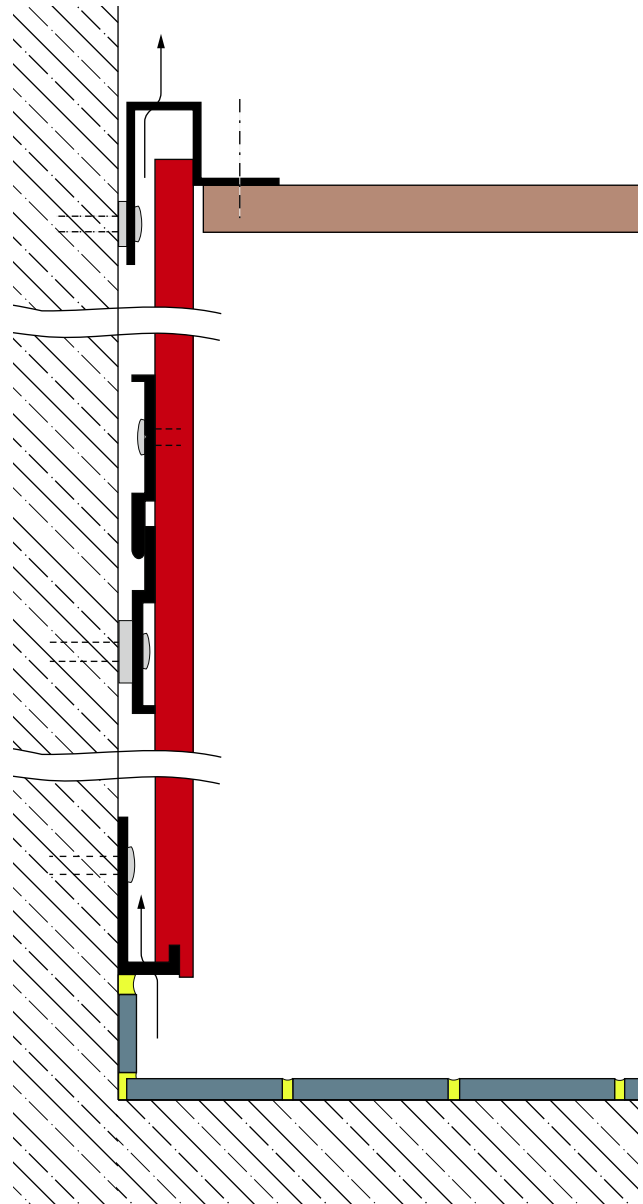

Horizontal cut of the ventilated wall cladding with Lohr wall protection profile

Fig. 82



Fig. 83

Wall Cladding

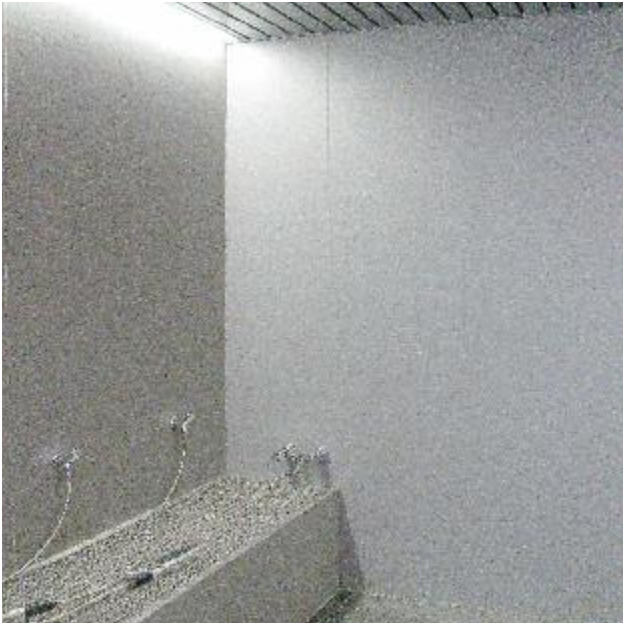
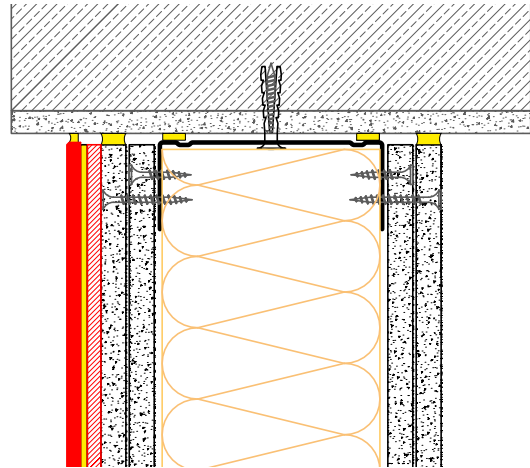

Fig. 84

Non-ventilated wall cladding with Max Alucompact06

Non-ventilated wall cladding is used for clean rooms and rooms with an important requirement of clean conditions. As the joints are clad, these panels can stand up to aggressive cleaning products and steam cleaners. Typical uses include wall cladding in operating theaters.

Advice: A substructure must be provided, even in non-ventilated wall cladding!



Horizontal section of the ceiling connection

Fig. 85

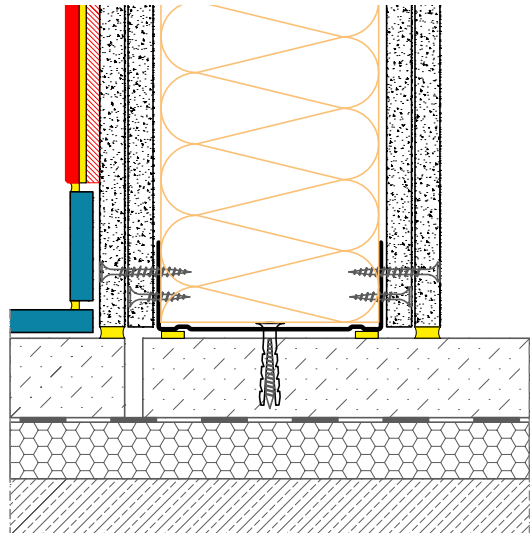

Horizontal section of the ground connection tiles

Fig. 86

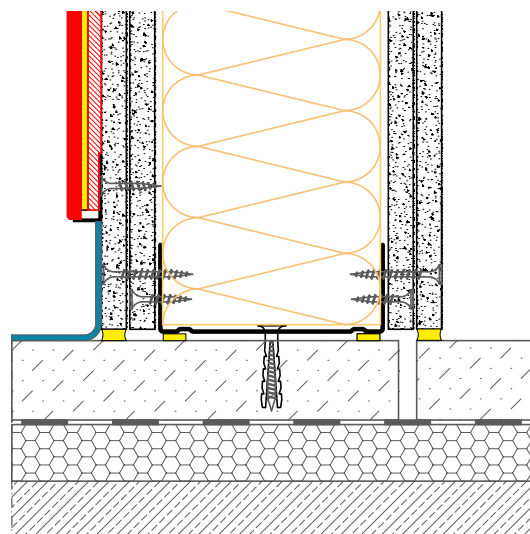

Horizontal section ground connection with aluminium profile

Fig. 87

Corner construction

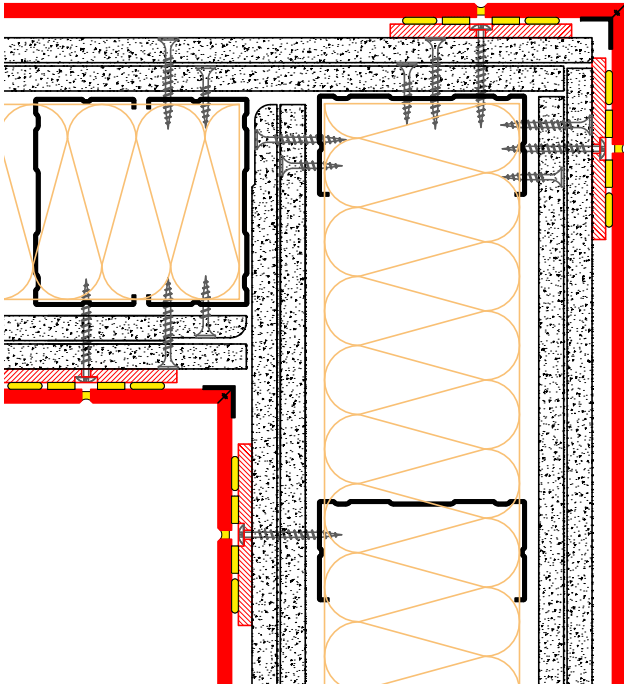

Horizontal section for the construction of corners both internally and externally

Fig. 88

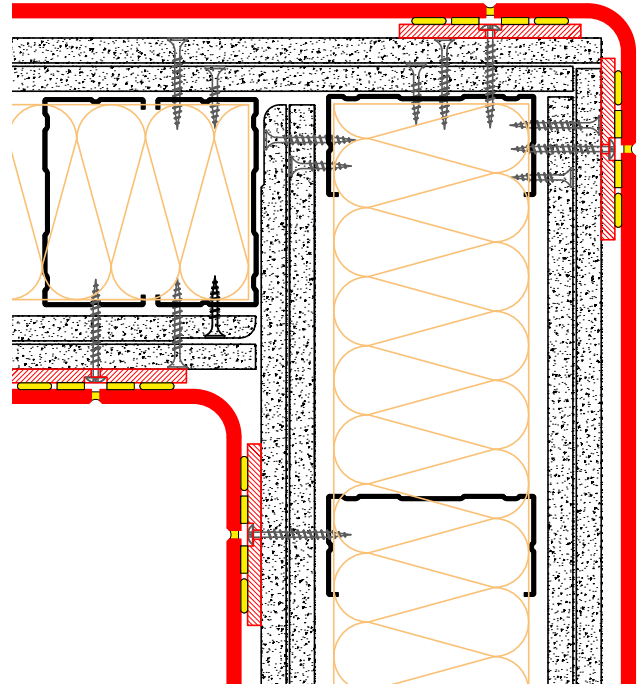

horizontal cut for the construction of corners with Max Compactforming elements

Fig. 90

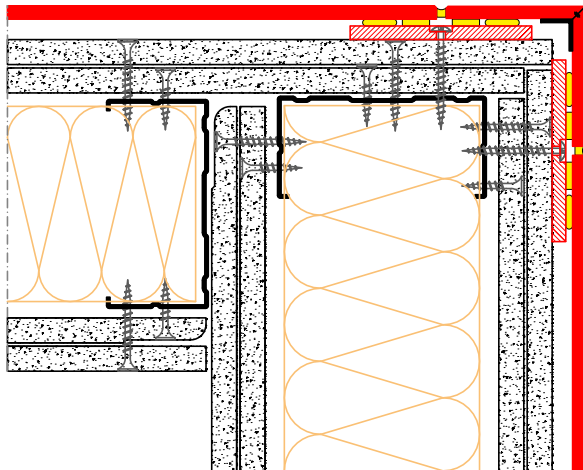

Horizontal cut for the construction of the corners externally; bevel adhered Max Compactforming elements

Fig. 89

You will find CAD sketches in the Download section of our website: www.fundermax.at

Wall Cladding

Corner construction with metal profiles

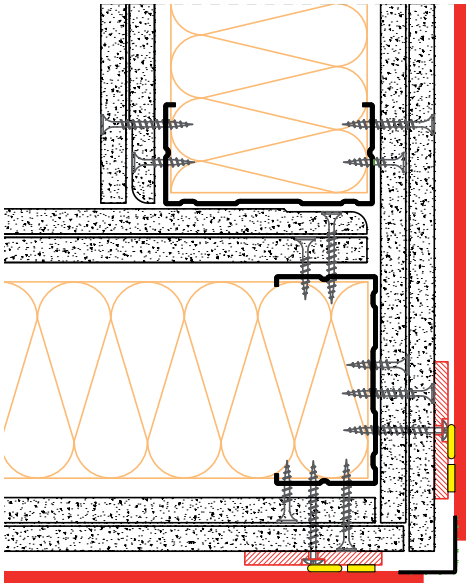

Horizontal section border connection corner profile -variant

Fig. 91

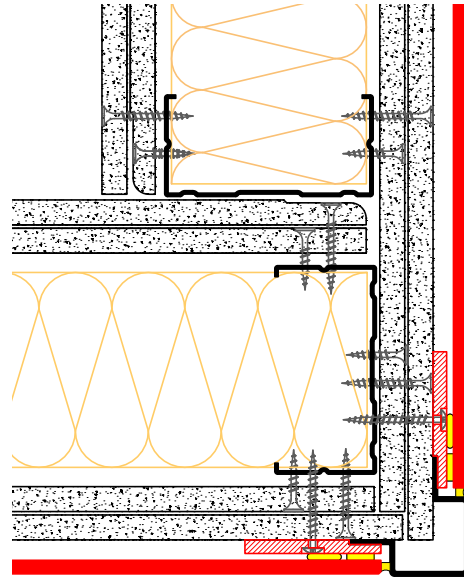

Horizontal section border connection corner profile

Fig. 94

Upper and lower borders of the skirting protection

Integrated to the plasterboard;
lower border non-integrated

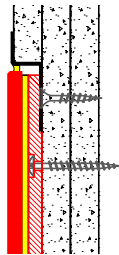

Upper connection for skirting protection

Fig. 92

Wall borders

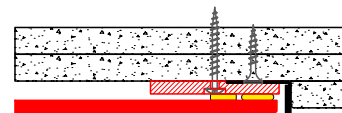

Horizontal section border connection corner profile

Fig. 95

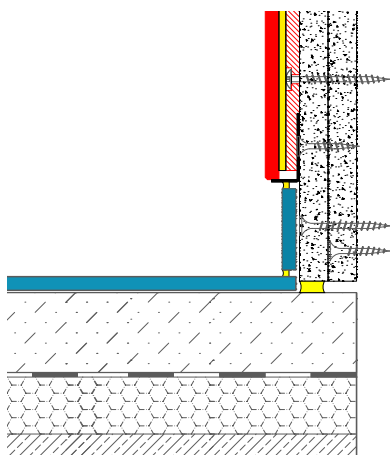

Lower connection of integrated skirting protection can not be integrated to plasterboard.

Fig. 93

Connections to the door frame

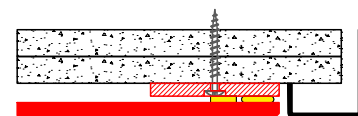

Horizontal section connection of the doorframe

Fig. 96

You will find CAD sketches in the Download section of our website: www.fundermax.at

Suppliers/accessories for wall cladding

Fastening device (mechanical):

Austria

EJOT AUSTRIA GmbH
Grazer Vorstadt 146
A-8570 Voitsberg
Tel.: +43 3142 / 276 00-0
Fax: +43 3142 / 276 00-30
info@ejot.at, www.ejot.at

SFS Intec GmbH
Wienerstraße 29
A-2100 Korneuburg
Tel.: +43 (0)2262 / 90500 102
Fax: +43 (0)2262 / 90500 930
www.sfsintec.biz

Germany

MBE GmbH
Siemensstraße 1
D-58706 Menden
Tel.: +49 (0)2373 17430 – 0
Fax: +49 (0)2373 17430 – 11
www.mbe-gmbh.de

Fischerwerke
Arthur Fischer GmbH&CoKG
Weinhalde 14-18
D-72178 Waldachtal/Tuurlingen
Tel.: +49 (0)7443 / 120
Fax: +49 (0)7443 / 1242 22
www.fischer.de

Netherlands

Ipex Europe B. V.
Vonderweg 14
NL-7468 DC ENTER
Tel.: +31 547 384 635
Fax: +31 547 384 637
www.ipex-group.com

Switzerland

SFS intec AG (Headquarters)
Rosenbergsaustasse 10
CH-9435 Heerbrugg
Tel.: +41 71 / 727 62 62
Fax: +41 71 / 727 53 07
gmi.heerbrugg@sfsintec.biz
www.sfsintec.biz

Fastening device (gluing):

Austria

Fassadenklebetechnik Klug GmbH
Zentrale
Julius-Tandler-Platz 6/15
A-1090 Wien
Tel.: +43 (0)676 / 727 1724
r.klug@fassadenklebetechnik.at
office@fassadenklebetechnik.at
www.fassadenklebetechnik.at

INNOTEK Industries
VertriebsgmbH
Boden 35
A-6322 Kirchbichl
Tel.: +43 (0)5332 / 71138
Fax: +43 (0)5332 / 72891
www.innotec.at

PROPART Handels GmbH
Lauchenholz 28
A-9123 St. Primus
Tel.: +43 (0) 4239 40 300
Fax: +43 (0) 4239 40 300-20
www.fassaden-kleben.at

Germany

Walter Hallschmid GmbH&Co.KG
Wiesentraße 1
D-94424 Arnsdorf
Tel.: +49 (0)8723 / 96 121
Fax: +49 (0)8723 / 96 127
www.dichten-und- kleben.de

MBE GmbH
Siemensstraße 1
D-58706 Menden
Tel.: +49 (0)2373 / 17430 – 0
Fax: +49 (0)2373 / 17430 – 11
www.mbe-gmbh.de

Switzerland

SIKA Chemie GmbH
Tüffenwies 16-22
CH-8048 Zürich
Tel.: +41 (0)1 / 436 40 40
Fax: +41 (0)1 / 270 52 39
www.sika.ch

Further adhesive suppliers

To aid your understanding, glue manufacturer products have been used in this chapter. The adhesive systems of other manufacturers may also be used. This list is by no means a complete version. For the list of glue and adhesive suppliers as well as adhesives, there are no technical regulations in Germany. Before mounting, technical approval and processing regulations must be obtained from the manufacturer!

SIKA Österreich GmbH
Lohnergasse 3
A-1210 Wien
Tel.: +43 (0)1 / 278 86 11
Fax: +43 (0)1 / 270 52 39
www.sika.at

DKS Technik GmbH
Gnadenwald 90A
A-6069 Gnadenwald
Tel.: +43 (0)5223 / 48 488-12
Fax: +43 (0)5223 / 48 488-50
www.dks.at

SOUDAL N.V.
Olof-Palme-Str. 13
D-51371 Leverkusen
Tel.: +49 (0)214 / 6904-0
Fax: +49 (0)217 / 6904-23
www.soudal.com

Profiles/accessories:

Austria

Protektor Bauprofile GmbH
Hosnedlgasse 12
A-1220 Wien
Tel.: +43 (0)1 / 259 45 00-0
Fax: +43 (0)1 / 259 45 00-19
www.protektor.com

Fa. Helmut Lohr
Elisabethstraße 36
A-2380 Perchtoldsdorf
Tel.: +43 (0)669 / 11506880
Fax: +43 (0)1 / 867 48 29
E-Mail: info@lohrshop.com

Germany

Protektorwerk
Florenz Maisch GmbH & Co.KG
Viktoriastraße 58
D-72571 Gaggenau
Tel.: +49 (0)7225 / 977-0
Fax: +49 (0)7225 / 977-111
info@protektor.com
www.protektor.com

France

PROTEKTOR S.A. BATI-PROFIL
Rue Pasteur Prolongée
F-94400 Vitry sur Seine
Tel.: +33 (0)1 / 55 53 17 50
Fax: +33 (0)1 / 55 53 17 40

Correctors (paints)

Austria

VOTTELER Lacktechnik GmbH
Malvenstraße 7
A-4600 Wels
Tel.: +43 (0)7242 / 759-0
Fax: +43 (0)7242 / 759-113
at.info@votteler.com
www.votteler.com

Germany

Heinrich König & Co. KG
An der Rosenhelle 5
D-61138 Niederdorfelden
Tel.: +49 (0)6101 / 53 60-0
Fax: +49 (0)6101 / 53 60-11
info@heinrich-koenig.de
www.heinrich-koenig.de

FSG Schäfer GmbH
Boschstraße 14
D-48703 Stadtlohn
Tel.: +49 (0)2563 / 9395-0
Fax: +49 (0)2563 / 9395-25
verkauf@fsg-schaefer.de
www.fsg-schaefer.de



Fig. 97

Due to their water-resistance, and hygienic surfaces, FunderMax Compact Interior panels are particularly suitable for use in wet rooms, shower screens, therapy rooms and changing rooms. Using these panels, architects and builders can ensure that the environmental and functional requirements are fully met.

Technical note on the use of FunderMax Compact Interior panels

■ Throughout the construction and mounting process it is particularly important to ensure that the material is not exposed to stagnated moisture. The panel material must always be able to dry out. For shower facilities which will be exposed to prolonged use, a sufficient ventilation system in the room is important.

■ Due to the material characteristics, it must thoroughly be ensured that during the adhesion process of FunderMax Compact Interior panels to one another (doubling, corner joints or bevelling), all bonded parts have the same fibre direction. This means that attachments should be made solely length to length and breadth to breadth. The remaining panels must always be indicated with the production direction. Corner joints must be mechanically supported through the use of dowels, springs, special milling procedures etc.

■ For high levels of moisture e.g. shower cubicles or similar, a mechanical connection of joints is indispensable when combined with an elastic and watertight bonding adhesive system.

The same logically applies to Max Compact moulded parts and folded moulded parts. When processing these parts it must be ensured, that cuts are not made directly in the area of the rounded curves. It is advisable to keep the shaft side narrow (see permitted tolerances in the current delivery programme). We reserve the right to make changes that affect the technical progress.

For the construction of cubicles from FunderMax Compact Interior panels, you have the possibility to choose from our extensive range of colours from the Fundermax collection. Please consult our current valid delivery programme. The construction elements described in this brochure 'Compact Interior technology' are suitable for all areas of use of FunderMax Compact Interior panels. If other profiles, fixtures etc. are used, these must be provided in stainless steel quality if used in wet or damp rooms (Nirosta, brass, aluminium).

Construction examples

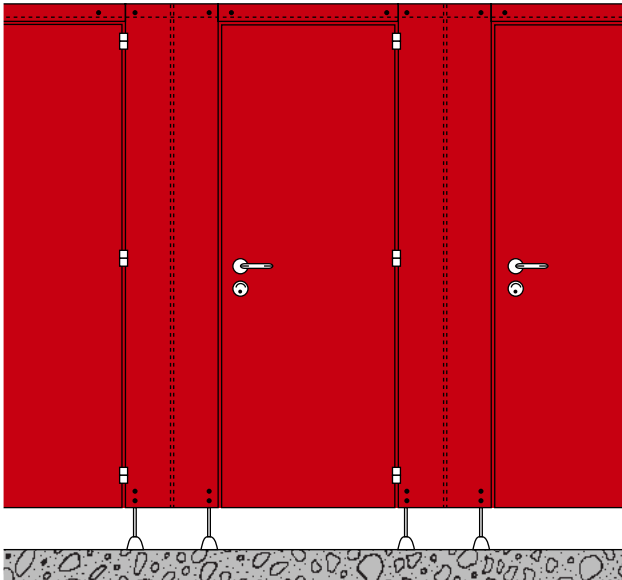

Cubicles with separating wall supports

Fig. 98a

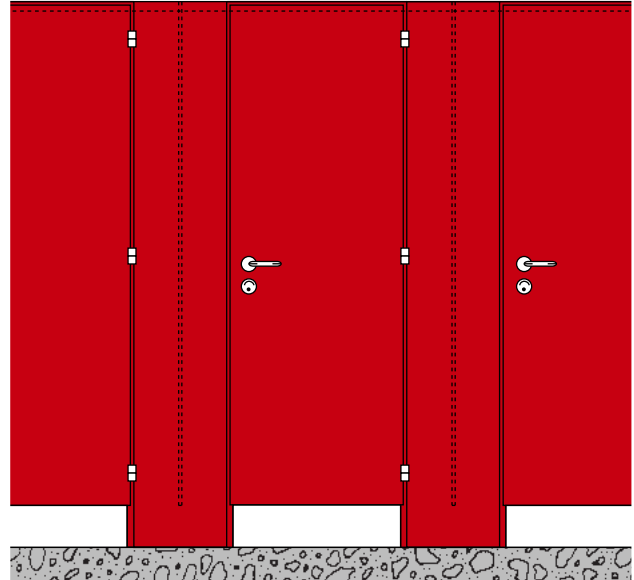

Cubicles with Max Compact forming-pillars

Fig. 99a

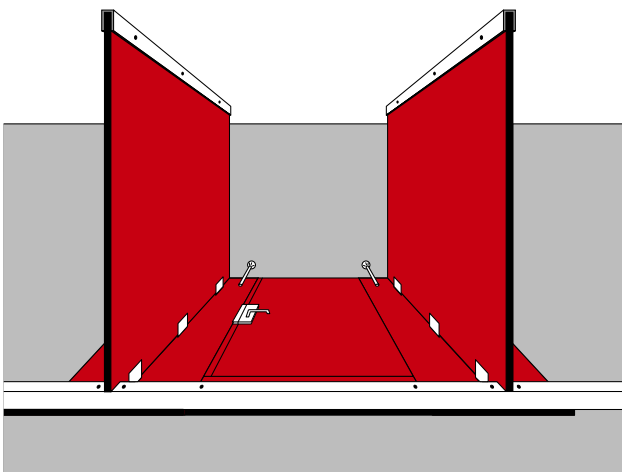

Fig. 98b

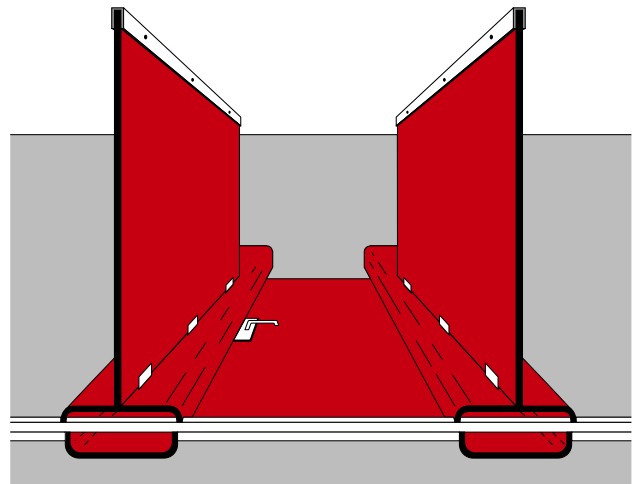

Fig. 99b

The construction examples on the following pages merely show a few possibilities for cubicle construction. Requirements may vary depending on construction and fittings. As regards the panel thickness however, it is recommended that FunderMax Compact Interior panels with a thickness of 13 mm be used under all circumstances.

Cubicles

Construction examples



A front panel reaching down to the ground

Fig. 100a

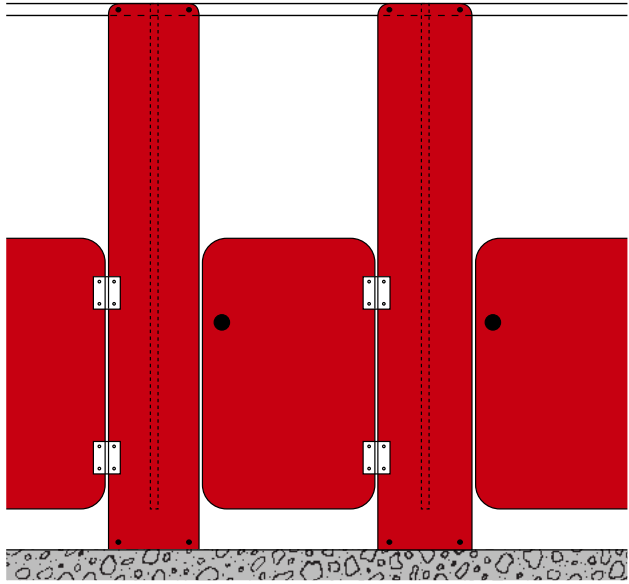

Cubicles with closing doors (spring hinges) for showers or nursery school toilets

Fig. 101a

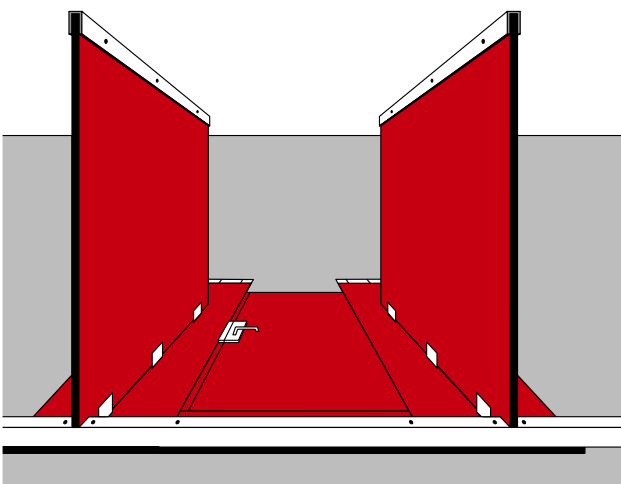

Fig. 100b

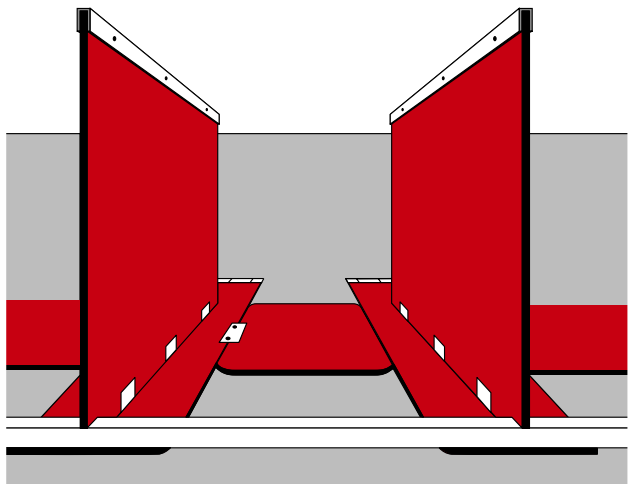
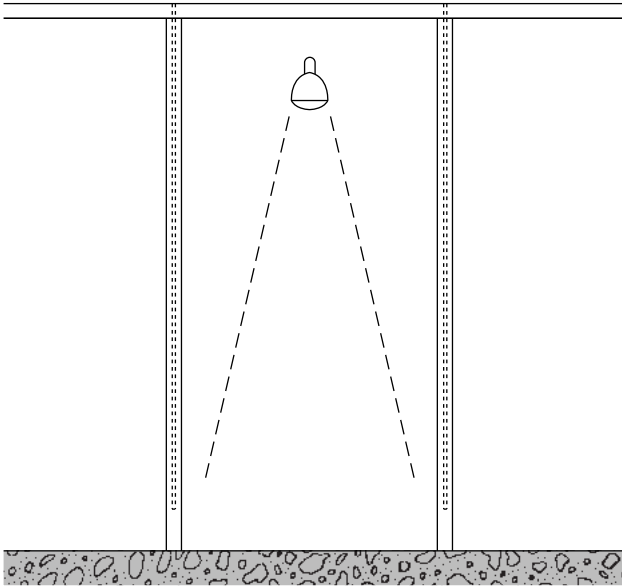

Fig. 101b

Construction examples



Shower divider with uprights and lintel profile made from forming tube

Fig. 102a

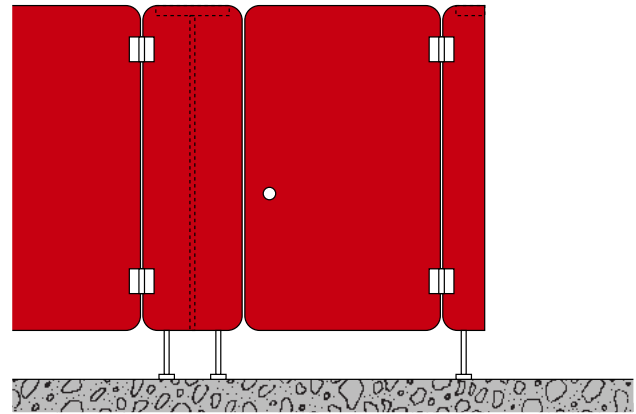

Cubicles for nursery school toilets

Fig. 103a

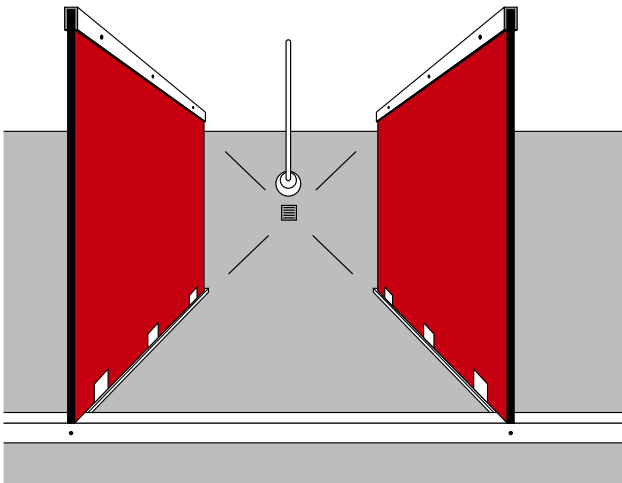

Fig. 102b

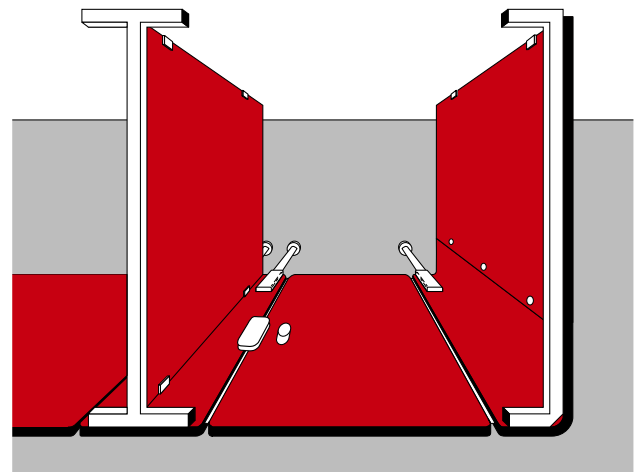

Fig. 103b

Construction details

Floor connections

In order to balance out uneven ground surfaces, but also to protect the FunderMax Compact Interior panels from a build-up-of water, foot supports from various suppliers are used (see suppliers/accessories for cubicles p. 69).

■ Wall separating supports

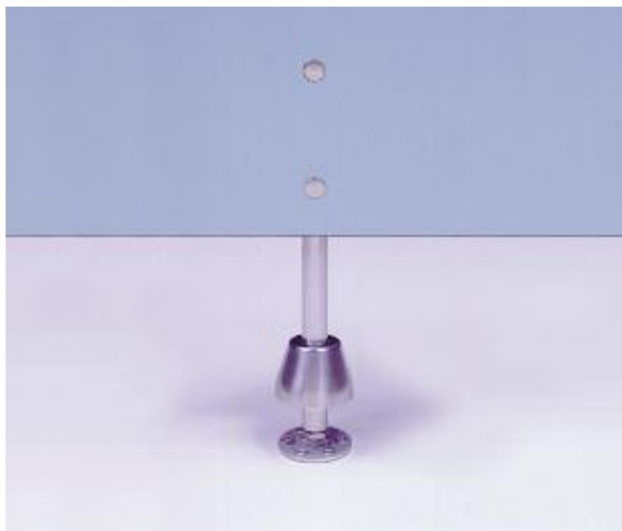

Supports with height adjustment, exterior view

Fig. 104

■ Wall separating supports with in-built height adjustment

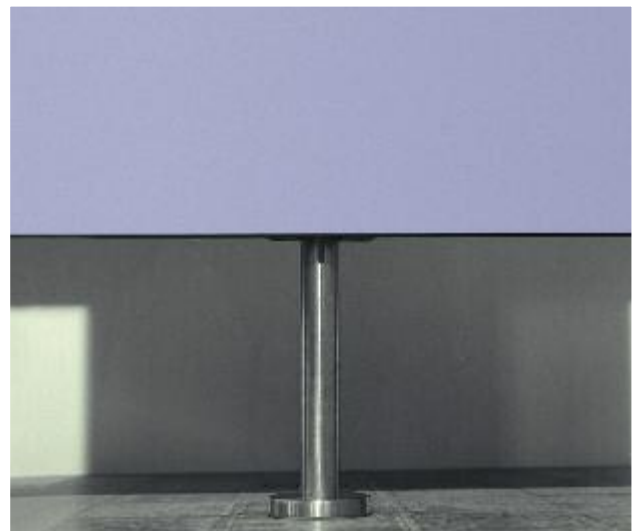

Height adjustment in-built supports, exterior view

Fig. 106



Supports with height adjustment, interior view

Fig. 105



Height-adjustable in-built supports, interior view

Fig. 107

Construction details

Floor connections

■ L-profile natural anodised aluminium

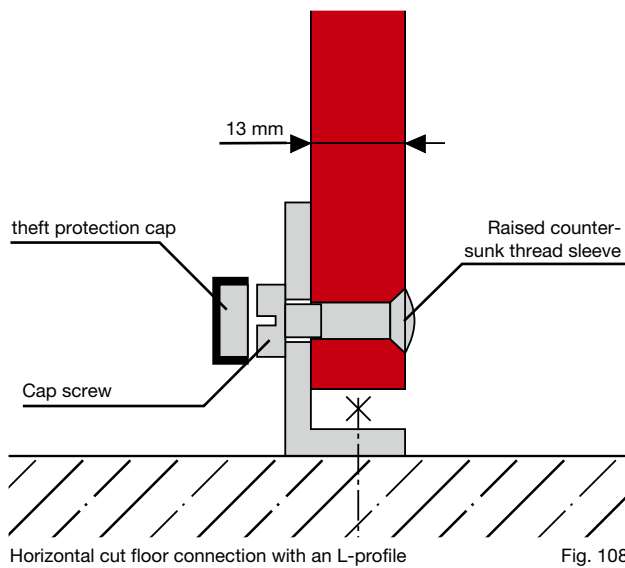

Fig. 108

■ Floor connection for frontal uprights (for shower and screen walls) and cubicles

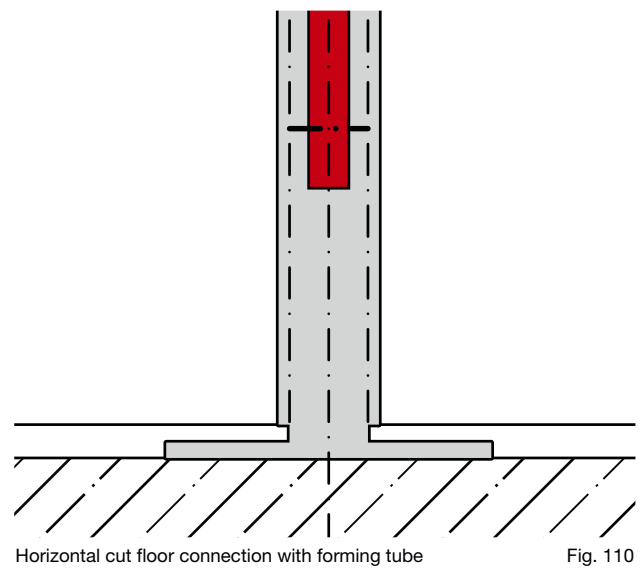

Fig. 110



Floor connection with L-profile

Fig. 109

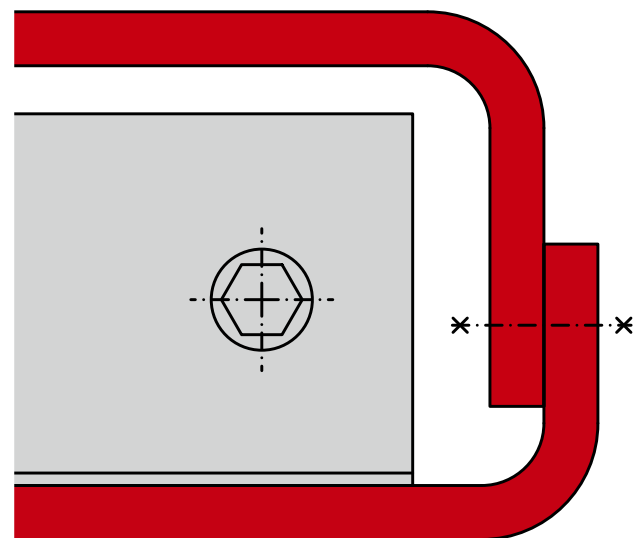

Fig. 111

Cubicles

Construction details

Connections of separating agents

For attaching FunderMax Compact Interior panels to the wall aluminium, stainless steel or plastic brackets can be used.

■ Stainless steel wall connecting component with 2 black end caps



Fig. 112

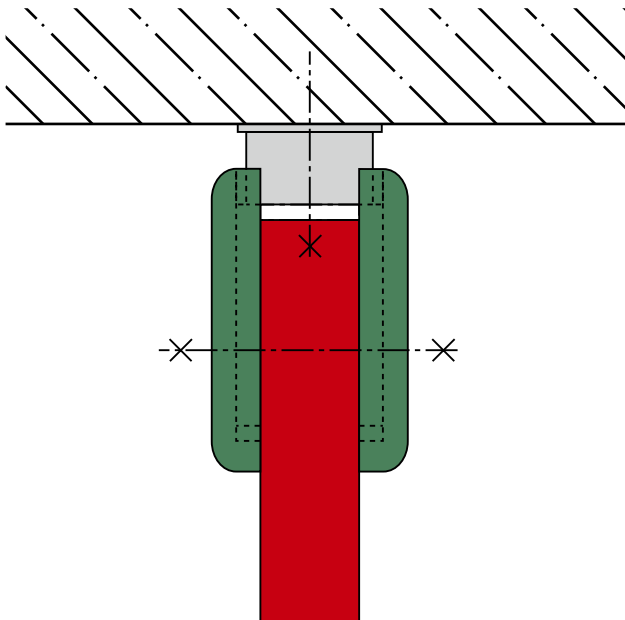

Horizontal section

Fig. 113

■ Wall separating connection brackets made from plastic for the connection of the front components, to the outside walls.

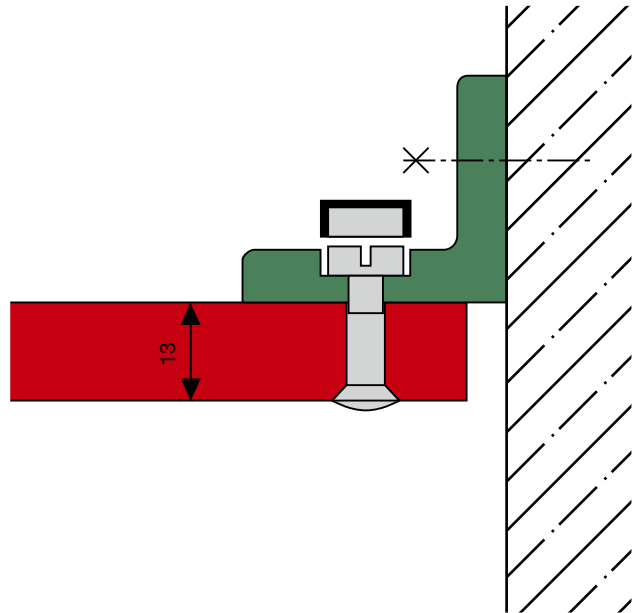

Horizontal section

Fig. 114



Fig. 115

Large expansion area ≤ 12 mm, meaning that a lateral adjustment is largely unnecessary. Access is however, not possible.

Construction details

Wall connections

■ U-profile anodised aluminium for a connection of the separating screens to the wall for 13 mm FunderMax Compact Interior panels

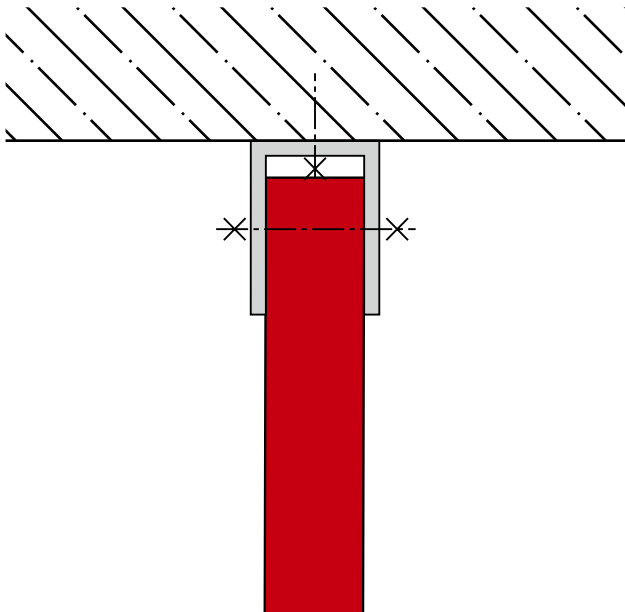

Horizontal section

Fig. 116

■ 2 separating wall end brackets made from plastic with 13 mm lights for FunderMax Compact Interior panels

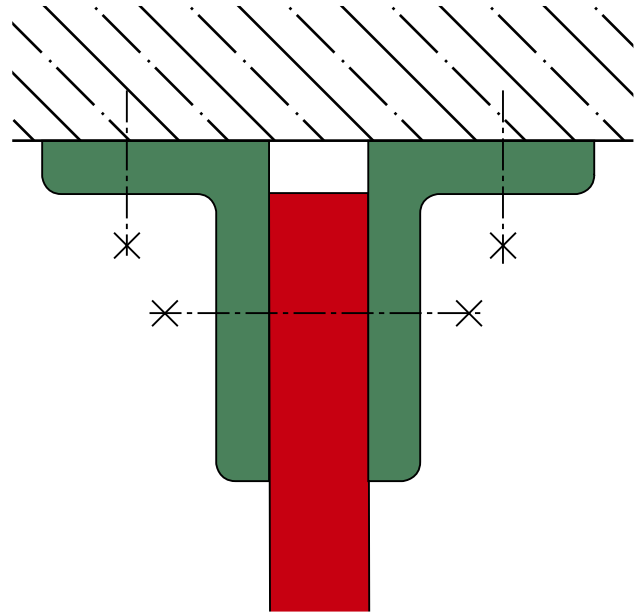

Horizontal section

Fig. 117



Fig. 118

Cubicles

Construction details

Wall connections

■ Trax-coupling for the connection of the separating walls to the front screens with 2 black cover plates for 13 mm thick panels.

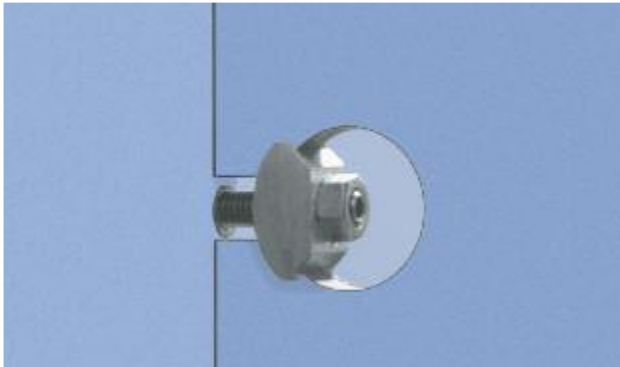

Trax-coupling open

Fig. 119

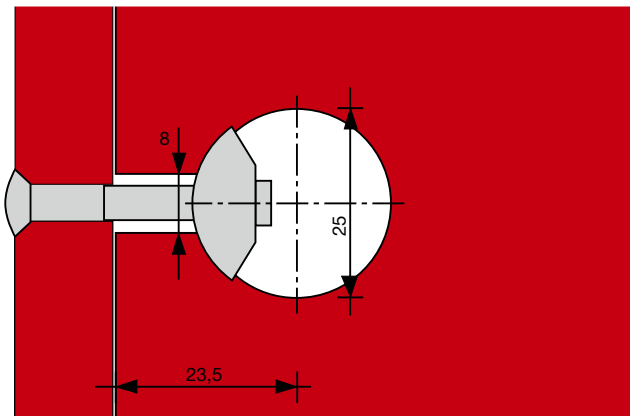

Fig. 120

■ Connection of the separating wall to the upright frame



Fig. 122



Side-view of the coupling drilling

Fig. 121

Construction details

Door support profiles and lintel profiles

■ Lintel profile

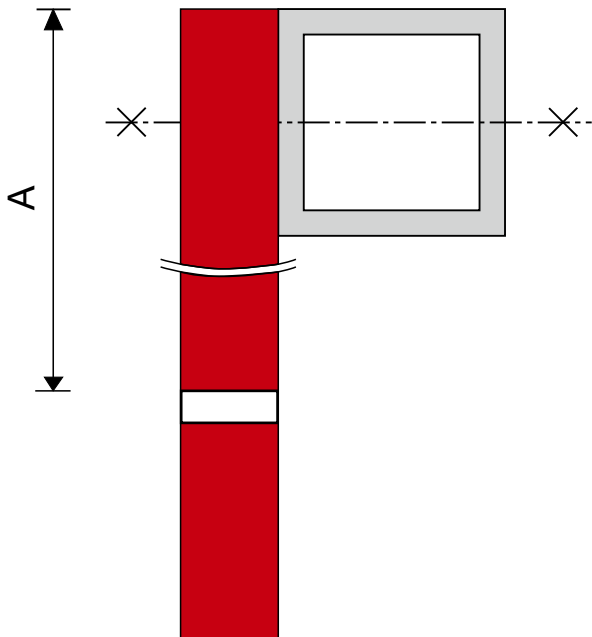

Vertical section of the lintel profile above the door

Fig. 123



Fig. 124



Fig.125

Support area for inwards opening doors a minimum of 80 mm high, in order to be able to hang the door, dimension A.

Construction details

Panel connections

For the connection of FunderMax Compact Interior panels, a separating wall panel thickness of 13 mm

■ Couplings for panel connections

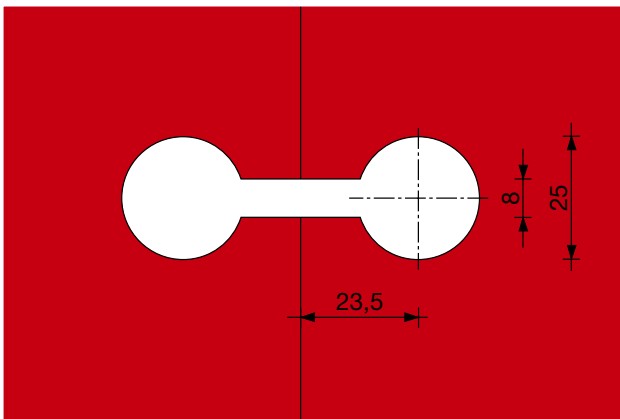

View of milling out for coupling

Fig. 126

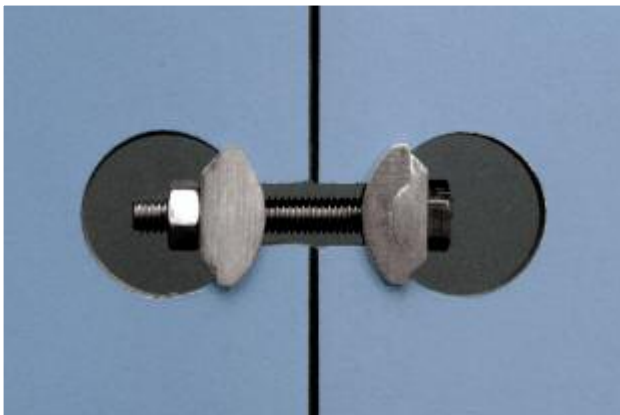

Straining screw

Fig. 127



Fig. 128

■ Over - panelling

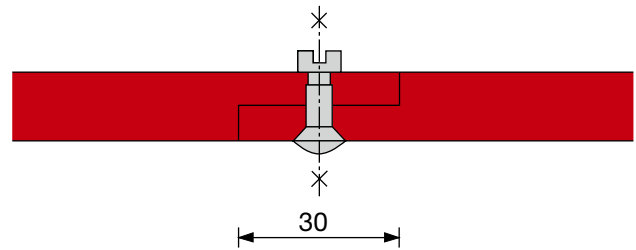

Horizontal section - over - panelling

Fig. 129

The over-panelling must be at least 30 mm wide, glued with PUR glue and 3 to 4 screws in addition.

For walls wider than 1300 mm, a stiffening profile and a support must be provided.

Construction details

Pillar cubicles

■ The front pillars are assembled from two Compact-forming U-elements with 4.8 x 25 mm pop-rivets. At one floor angle, which is fixed with 2 heavy-duty screw plugs, the pillar is screwed in with 4 Parker screws. Floor angle, 4 galvanised Parker screws.

■ When screwing across the edge, pay close attention to the drill diameter! Please make a template. The Compact screw-on lock is used without an opposing socket for Compactforming pillars.



Cubicle system with Max Compactforming pillars

Fig. 132



Hinge inside

Fig. 130



Hinge outside

Fig. 131



Lock socket with striking plate

Fig. 133

Construction details

Pillar cubicles

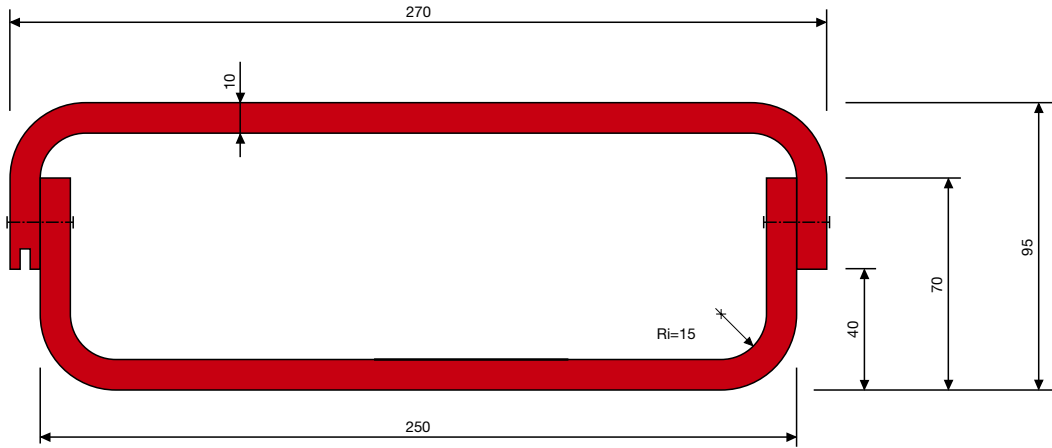

Horizontal section middle column from Max Compactforming elements

Fig. 134

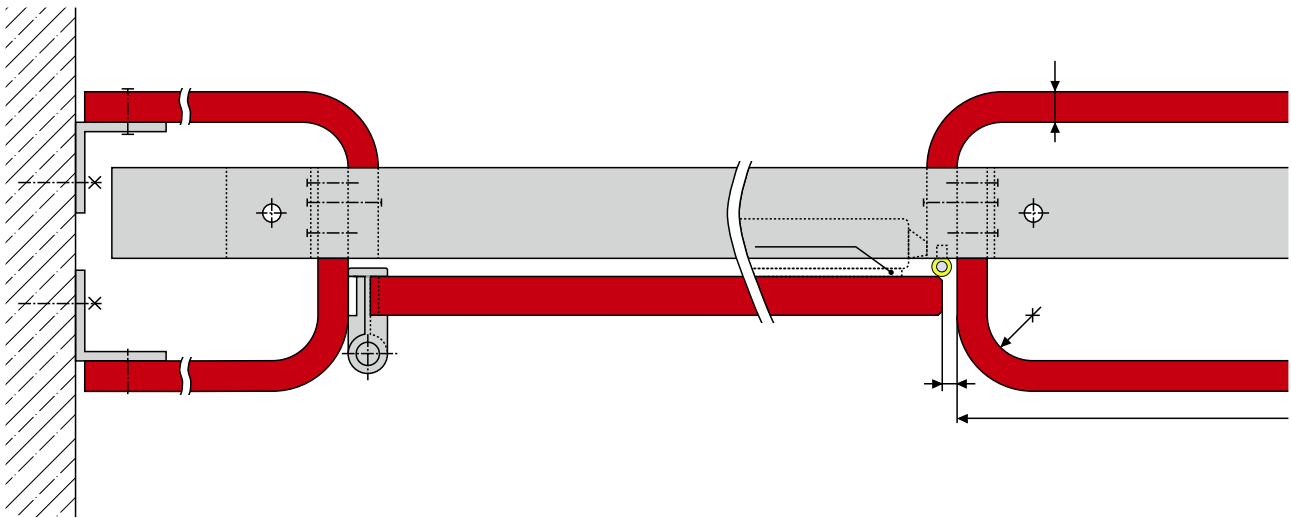

Horizontal section and half wall columns and door with middle column

Fig. 135

These examples only show some examples of the possibilities for cubicle construction. Requirements may vary depending on the construction and fittings. It is recommended that a panel thickness of 13 mm is used for FunderMax Compact Interior panels under all circumstances.

Construction details

Bench

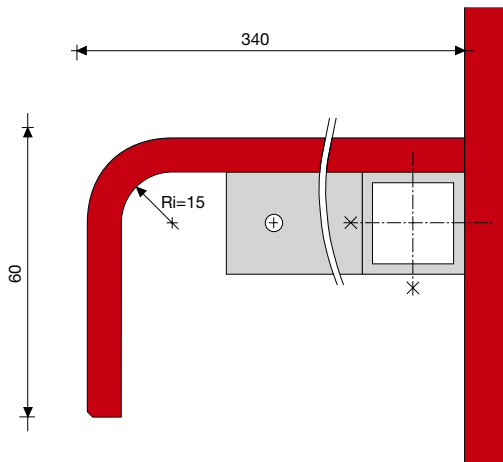

Vertical section - bench made from Max Compactforming

Fig. 136



Bench - mounting on aluminium structural tubing

Fig. 137

Suppliers/accessories for cubicles

Construction elements:

Schäfer Bädertechnik
Moselstr. 61
D-42579 Heiligenhaus
Tel.: +49 (0)2054 / 938 46 66
Fax: +49 (0)2054 / 938 46 67
schaefer@baedertechnik.com
www.baedertechnik.com

Normbau GmbH
Schwarzwaldstr. 15
D-77871 Renchen
Tel.: +49 (0)7843 / 704-0
Fax: +49 (0)7843 / 704-43
info@normbau.de
www.normbau.de

PBA s.r.l.
Via Enrico Fermi 1
I-36056 Tezze Sul Brenta (VI)
Tel.: +39 0424 / 54 51
Fax: +39 0424 / 545 222
info@pba.it
www.pba.it

PBA Deutschland
Raiffeisen Str. 4a
D-83607 Holzkirchen
Tel.: +49 (0)8024 / 60 84 694
Fax: +49 (0)8024 / 47 49 890
info@de.pba.it
www.corona-hv.de/pba.htm

Fa. Helmut Lohr
Elisabethstraße 36
A-2380 Perchtoldsdorf
Tel.: +43 (0)669 / 11506880
Fax: +43 (0)1 867 48 29
info@lohrshop.com

Fitting parts:

HEWI Heinrich Wilke GmbH
Postfach 1260
D-34442 Bad Arolsen
Telefon: +49 (0)5691 / 82-0
Telefax: +49 (0)5691 / 82-319
info@hewi.de
www.hewi.de

GM Zargenprofil Topglas
Glas Merte GmbH & Co KG
Brachsenweg 39
A- 6900 Bregenz
Te.: +43 (0)5574 / 67 22-0

Correctors (paints):

VOTTELER Lacktechnik GmbH
Malvenstraße 7
A-4600 Wels
Tel.: +43 (0)7242 / 759-0
Fax: +43 (0)7242 / 759-113
at.info@votteler.com
www.votteler.com

Heinrich König & Co. KG
An der Rosenhelle 5
D-61138 Niederdorfelden
Tel.: +49 (0)6101 / 53 60-0
Fax: +49 (0)6101 / 53 60-11
info@heinrich-koenig.de
www.heinrich-koenig.de

FSG Schäfer GmbH
Boschstraße 14
D-48703 Stadtlohn
Tel.: +49 (0)2563 / 9395-0
Fax: +49 (0)2563 / 9395-25
verkauf@fsg-schaefer.de
www.fsg-schaefer.de

Several accessories:

Schachermayer Großhandelsgesellschaft mbH
Schachermayerstr. 2-10
A-4021 Linz
Tel.: +43 (0)732 / 6599 - 0
Fax: +43 (0)732 / 6599 - 1360
zentrale@schachermayer.at
www.schachermayer.at

Hueck + Richter Aluminium GmbH
Rossakgasse 8
A-1230 Wien
Tel.: +43 (0)1 / 667 15 29-0
Fax: +43 (0)1 / 667 15 29-0
www.hueck.at

Pauli + Sohn GmbH
Eisenstraße 2
D-51545 Waldbröl
Tel.: +49 (0)2291 / 9206-0
Fax: +49 (0)2291 / 9206-681
www.pauli.de

SWS Ges. f. Glasbaubeschläge
Friedrich-Engels-Straße 12
Tel.: +49 (0)2291 / 7905-0
Fax: +49 (0)2291 / 7905-10
D-51545 Waldbröl
info@sws-gmbh.de
www.sws-gmbh.de

Lauterbach GmbH
Heraeusstraße 22
D-06803 Bitterfeld-Wolfen/OT Greppin
Tel.: +49 (0)3493 / 82 76 76
Fax: +49 (0)3493 / 92 29 06
info@lauterbach-gmbh.com
www.lauterbach-gmbh.com

Ceilings and ceiling claddings



Fig. 138

Visible mechanical fastening with rivets or screws

FunderMax Compact Interior panels can be mounted on an aluminium substructure using rivets or on a wooden substructure using screws. Due to the material characteristics of Max Compact Interior, fixed and slide points must be drilled for the mounting process.

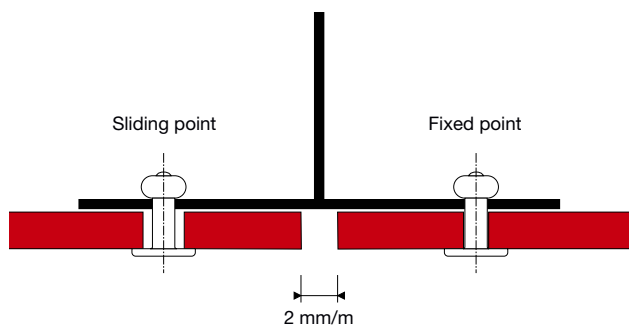

Fig. 139

Ventilation

As with wall cladding, sufficient ventilation must also be ensured when processing ceiling panels and cladding. (see chapter on wall cladding).

Sliding point

The diameter of the drill hole in FunderMax Compact must be drilled larger than the diameter of the fastening, depending on the required expansion clearance. This is the shaft diameter of the fastening plus 2 mm for every meter of cladding material starting from the fixed point.

The head of the fastening must be big enough so that the drill hole in Max Compact is always covered. The fastening is placed in such a way that the panel can move. The rivets must be put in place with a flexible mouthpiece. The defined distance allows a movement of the parts in the borehole (clearance 0.3 mm).

Screws must not be over-tightened. Do not use any countersunk screws.

Fixed point

The fixed point allows for the equal distribution (halving) of swelling and shrinking movements. The drill diameter in the FunderMax Compact panels should be the same size as the diameter of the mounting device.

Per panel, a fixed point is drilled as close to the middle as possible. All other fastening holes are drilled as slide points.

⊗ Fixed point

⊕ Sliding point

Space to the edges

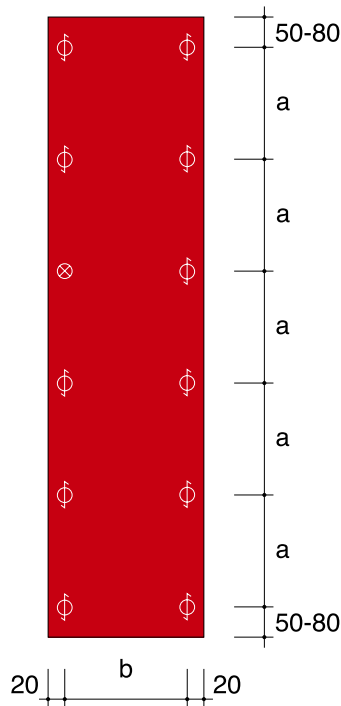

Single span panel

Fig. 140

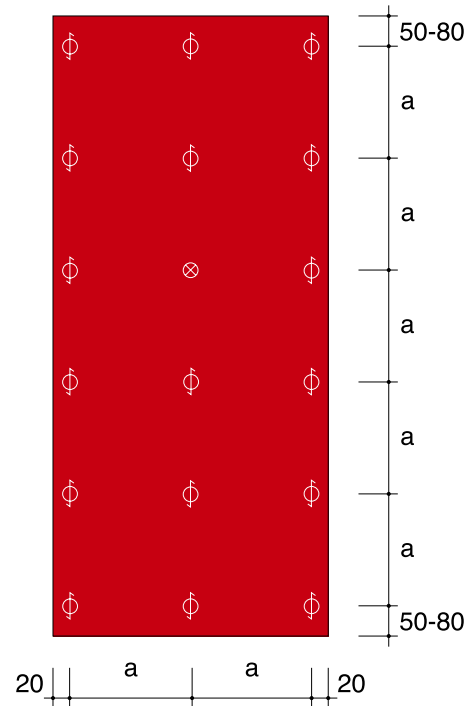

Double span panel

Fig. 141

For installation with mechanical fastenings

Panel thickness	maximum fastening spacing „b“ single span panel	maximum fastening spacing „a“ double span panel
6 mm	350 mm	400 mm
8 mm	400 mm	450 mm
10 mm	450 mm	500 mm

Table 20

Edge spacings

For reasons of stability and flatness, the edge spacings must be kept to without fail. The joints must be made at least 2 mm/m wide so that changes in size can take place without hindrance (Fig. 139).

Fastening spacings

These are to be chosen in accordance with the structural engineering requirements (calculations) or, if this is not necessary due to the local regulations, according to table no. 20.

Suppliers of fastening you will find on page 73 or at our Website www.fundermax.at

Fastenings

It is essential that only fastening materials made from non-corroding materials can be used.

Max Compact installation screw with Torx 20 stainless steel X5Cr Ni Mo 17122 material No. 1.4401 V4A. Painted head available upon request. Drill diameter in Max Compact for installation with screw
 sliding points: 8 mm or as required.
 Fixed point: 6 mm

Alu-Blind rivet with big head colour lacquered or with covering cap for wall claddings with FunderMax Compact panels on aluminium-substructures.
 Rivet sleeve: EN AW-5019 acc. DIN EN 755-2
 Rivet pin: steel material-no. 1.4541
 Pull-off strength of rivet pin: ≤ 5,6 KN
 lacquered head on request.

Diameter of drill hole in Max Compact for installation with rivets
 Sliding points: 8,5 mm or as required
 Fixed points: 5,1 mm

Diameter of drill hole in aluminium substructure: 5,1 mm
 The rivets must be put in place with a flexible mouthpiece, clearance 0.3 mm. The rivet, flexible mouthpiece and riveting tool must be suited to each other.

Ceilings and ceiling claddings



Fig. 142

Secret fastening with adhesive system

FunderMax Compact Interior panels can be attached to aluminium substructures using adhesive systems. The stability of the structure must be tested using static objects.

It is important that the respective construction supervisory body on a local or national level grants authorisation. Due to the different regional building regulations (building codes), the construction supervisory board can demand for additional support structures by means of mechanical fixings (rivets, screws etc.). The adhesion must be carried out following the processing regulations from the adhesive system manufacturer. FunderMax recommends using adhesive systems which are also approved by the building authorities for the mounting of curtain-type ventilated facades.

The following listed points must be considered throughout the working process:

Pretreatment of aluminium substructures

- Sanding with abrasive fleece
- Pretreatment with cleaning product provided by the adhesive manufacturer
- Application of the primer following the recommendations of the adhesive manufacturer

Pretreatment of FunderMax Compact panels

- Sanding with abrasive fleece
- Pretreatment using the cleaning product provided by the adhesive manufacturer
- Application of the primer following the recommendations of the adhesive manufacturer. All adhesive surfaces must remain clean, dry and grease-free. Throughout the construction process it must be ensured that the adhesive system is not exposed to any stagnated moisture.

Suppliers/accessories for ceilings and ceiling cladding

Fastening material (mechanical):

Austria

EJOT AUSTRIA GmbH
Grazer Vorstadt 146
A-8570 Voitsberg
Tel.: +43 3142 / 276 00-0
Fax: +43 3142 / 276 00-30
info@ejot.at, www.ejot.at

SFS Intec GmbH
Wienerstraße 29
A-2100 Korneuburg
Tel.: +43 (0)2262 / 90500 102
Fax: +43 (0)2262 / 90500 930
www.sfsintec.biz

Germany

MBE GmbH
Siemensstraße 1
D-58706 Menden
Tel.: +49 (0)2373 17430 – 0
Fax: +49 (0)2373 17430 – 11
www.mbe-gmbh.de

Fischerwerke
Arthur Fischer GmbH&CoKG
Weinhalde 14-18
D-72178 Waldachtal/Tuurlingen
Tel.: +49 (0)7443 / 120
Fax: +49 (0)7743 / 1242 22
www.fischer.de

Netherlands

Ipex Europe B. V.
Vonderweg 14
NL-7468 DC ENTER
Tel.: +31 547 384 635
Fax: +31 547 384 637
www.ipex-group.com

Switzerland

SFS intec AG (Headquarters)
Rosenbergsaustasse 10
CH-9435 Heerbrugg
Tel.: +41 71 / 727 62 62
Fax: +41 71 / 727 53 07
gmi.heerbrugg@sfsintec.biz
www.sfsintec.biz

Profiles/accessories:

Austria

Protektor Bauprofile GmbH
Hosnedlgasse 12
A-1220 Wien
Tel.: +43 (0)1 / 259 45 00-0
Fax: +43 (0)1 / 259 45 00-19
www.protektor.com

Fa. Helmut Lohr
Elisabethstraße 36
A-2380 Perchtoldsdorf
Tel.: +43 (0)699 / 11506880
Fax: +43 (0)1 / 867 48 29
info@lohrshop.com

Germany

Protektorwerk
Florenz Maisch GmbH & Co.KG
Viktoriastraße 58
D-72571 Gaggenau
Tel.: +49 (0)7225 / 977-0
Fax: +49 (0)7225 / 977-111
info@protektor.com
www.protektor.com

France

PROTEKTOR S.A. BATI-PROFIL
Rue Pasteur Prolongée
F-94400 Vitry sur Seine
Tel.: +33 (0)1 / 55 53 17 50
Fax: +33 (0)1 / 55 53 17 40

Correctors (paints):

Austria

VOTTELER Lacktechnik GmbH
Malvenstraße 7
A-4600 Wels
Tel.: +43 (0)7242 / 759-0
Fax: +43 (0)7242 / 759-113
at.info@votteler.com
www.votteler.com

Germany

Heinrich König & Co. KG
An der Rosenhelle 5
D-61138 Niederdorfelden
Tel.: +49 (0)6101 / 53 60-0
Fax: +49 (0)6101 / 53 60-11
info@heinrich-koenig.de
www.heinrich-koenig.de

FSG Schäfer GmbH
Boschstraße 14
D-48703 Stadtlohn
Tel.: +49 (0)2563 / 9395-0
Fax: +49 (0)2563 / 9395-25
verkauf@fsg-schaefer.de
www.fsg-schaefer.de

Table tops



Fig. 143

Application

FunderMax Compact Interior panels are often used as table tops for school, desk, office, conference, lab or factory tables.

Resistance

Due to their pore-free surfaces and excellent chemical resistance, FunderMax Compact Interior panels are very easy to clean. Further advantages of these panels include their high scratch, tear and impact resistance.

Storage

Neither tables nor table panels should be stacked as the heavy stack weight can lead to damage.

Panel thickness

The thickness of Max Compact Interior table panels should either be 12 mm, or at least 10 mm, in order to allow enough depth for screwing. Both panel thickness and mounting distances as well as expected load platforms, are directly linked and must be measured correspondingly. For very heavy loads, we recommend using Max Alucompact42.

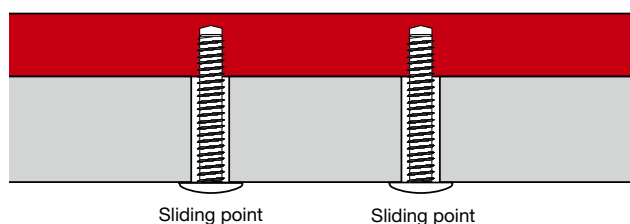

Fig. 144

Fastening

The fastening of Compact Interior panels can be carried out in a number of different ways, however, due to the material characteristics, a linear free expansion must be considered during the mounting process. The panels can be mounted mechanically using screws. The screws can either be directly screwed into the panels or inserted using sleeve screws with internal and external threads (e.g. Rampa inserts). For this, the panels must be pre-drilled for to establish a thread. Fastening the panels using screws takes place from the underside of the material. Therefore, metric thread and flat-head screws are suitable. Washers can be used if required.

Due to Compact material characteristics, the fixing points must be sliding points.

Sliding point: The drill diameter in the substructure must be bigger than that of the mounting material depending on the corresponding Compact expansion room. The screw head should always cover the bore-hole. The mounting material will be attached in such a way that the panels are free to move. Screws should not be too tightly fastened. The middle point of the drilling in the substructure should correspond with the middle point of the drilling in the Max Compact.

Drill with centering sleeve! The fastening material should be attached from the middle of the panel outwards.

Fastening spacings

Max Compact Interior		
Thickness (mm)	Fastening-spacing (mm)	Projection (mm)
10	320	180
12	400	250

Table 21

Max Alucompact42		
Thickness (mm)	Fastening-spacing (mm)	Projection (mm)
10	500	300
12	640	400

Table 22

Examples of use with Max Compact Interior 12 mm

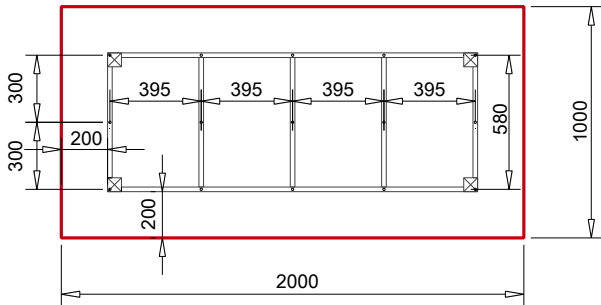

Fig. 145

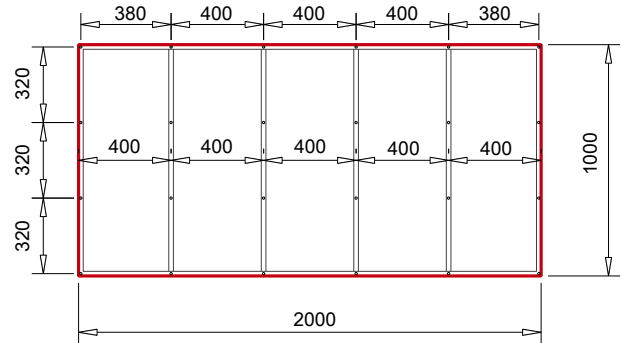

Fig. 149

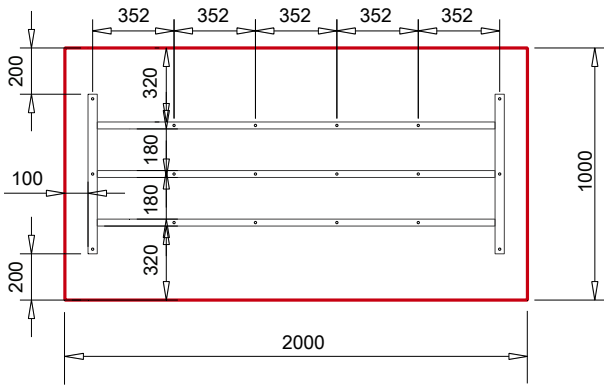

Fig. 146

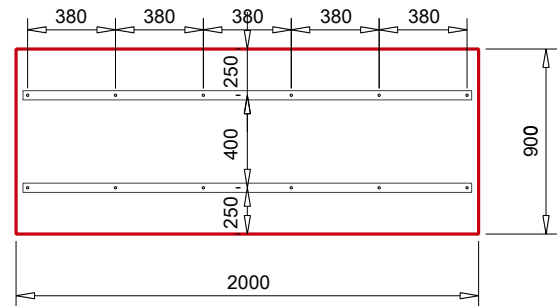

Fig. 150

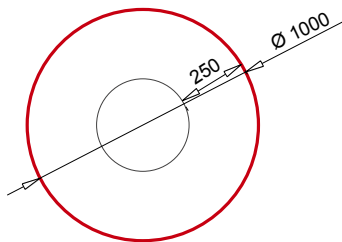

Fig. 147

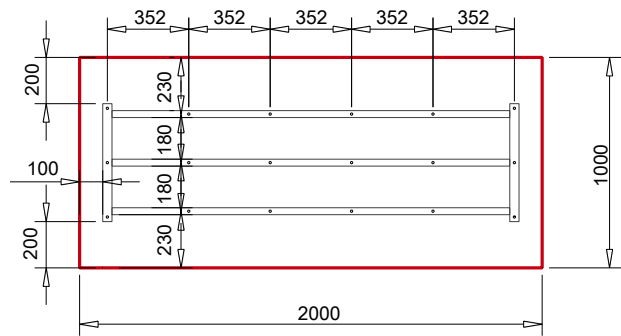

Fig. 151

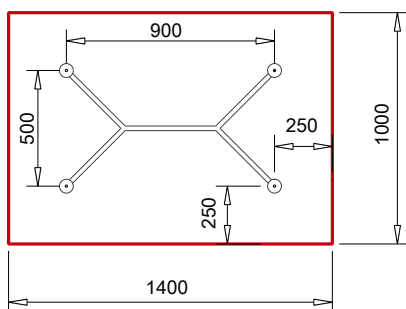

Fig. 148

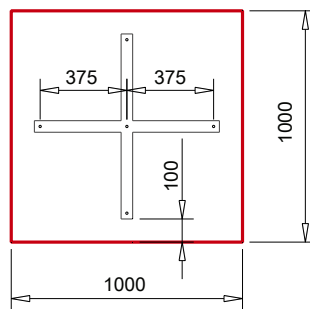

Fig. 152

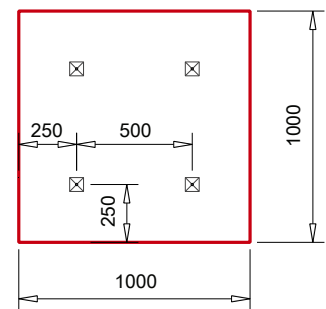

Fig. 153



Fig. 154

Cabinet body

FunderMax Compact Interior panels are suitable for shopfittings, design applications, hospitals or for home and office furniture.

In principle, the same panel connections used for conventional furniture construction can be used. However, as it is not necessary to use the same panel strengths, the panels must be selected correspondingly.

Due to the material characteristics of the FunderMax Compact Interior panels, both fixed and sliding points must be drilled. During the adhesion process of FunderMax Compact Interior panels to corner joints, stumps or bevel cuts, it must be ensured that all bonded elements have the same production direction. That means adhesions must solely be made length to length and breadth to breadth. The remaining panels must always indicate the machine direction.

Cabinet doors:

There are only several door hinges that are suitable for the thin panel thickness and therefore, door elements such as hinges can be doubled. It is important that the same panel material in the same thickness and decor is used in order to maintain symmetry.

Reactive adhesives are suitable for the adhesion process, for e.g. epoxy or solvent free PU glues (also see adhered corpus and corner joints).



Object hinge (Fa. Prämeta) for Compact doors panels, door thickness 10 -13 mm. Single axis pivot point.

Fig. 155



Unscrew strap hinges for doors made from Compact panels

Fig. 156

Mechanical corner joints

Due to the largely low material thickness, the recommended means of mounting are screwing or riveting (blind rivets). The drill diameter must be selected larger than the shaft diameter of the mounting materials (dimensional changes). In keeping with the larger screw heads, setting heads on rivets or washers should be used.

Max Compact Interior corner joints can be produced along the entire length using brackets. This is particularly necessary when covering large areas but also to support adhesive joints when used in wet rooms.

If the underside of the Max Compact panel above the substructure is being drilled from behind, fixed and slide points must be considered (as described in the table tops chapter). A minimum panel thickness of 13 mm is necessary to ensure sufficient drilling material

Further examples of mechanical connections:

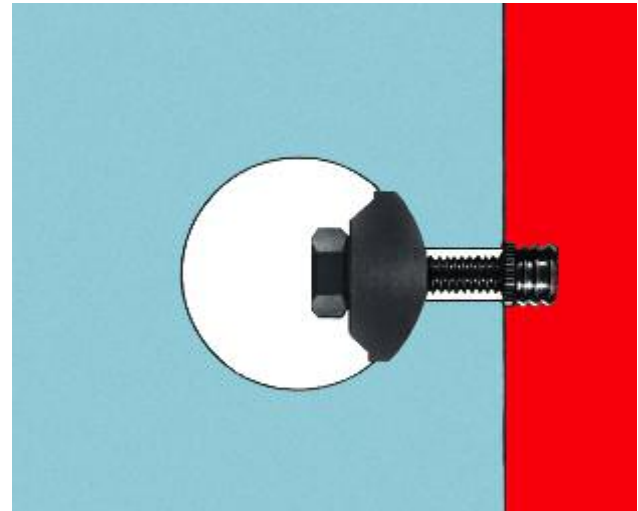

Connection with brass expansion bolt

Fig. 160

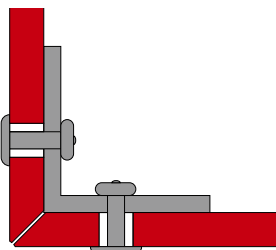

Fig. 157

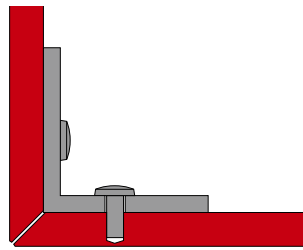
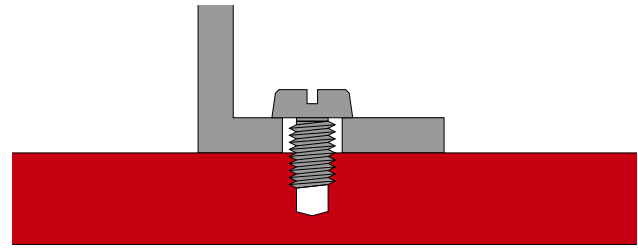

Fig. 158



Connection with the tapped hole directly into the Compact panel

Fig. 161

Thinner panels are drilled or riveted. The fixed and sliding points are ideally inserted into the panels.

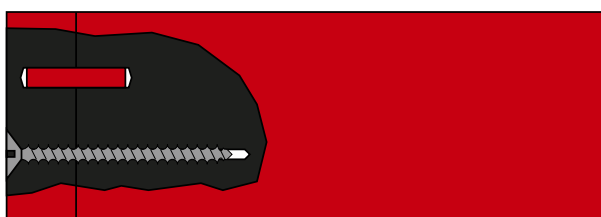

Fig. 159

Furniture

Application examples for furniture



Fig. 162



Fig. 164



Fig. 165



Fig. 163



Fig. 166

Suppliers/accessories for furniture construction

Fittings/fastening materials (mechanical):

Austria

Schachermayer-
Großhandelsgesellschaft m.b.H.
Schachermayerstraße 2
Postfach 3000
A-4021 Linz
Telefon: +43 (0)732 / 6599-0
Fax: +43 (0)732 / 6599-1360
info@schachermayer.at
www.schachermayer.at

Fa. Schmidschläger
Kaiserstraße 41
1070 Wien
Tel.: 01 / 523 46 52-0
Fax: 01 / 523 46 52-16
service@schmidtschlaeger.at
www.schmidtschlaeger.at

Häfele Austria GmbH
Römerstraße 4
A-5322 Hof bei Salzburg
Tel: +43(0)6229 / 39 0 39-0
Fax: +43 (0)6229 / 39 0 39-30
info@haefele.at
www.haefele.at

Germany

Häfele GmbH & Co KG
Adolf-Häfele-Str. 1
D-72202 Nagold
Tel: +49 (0)74 52 / 95-0
Fax: +49 (0)74 52 / 95-200
info@haefele.de
www.haefele.com

Hettich Holding GmbH & Co. oHG
Vahrenkampstraße 12-16
32278 Kirchlengern
Tel.: +49 5223 / 77-0
Fax: +49 5223 / 77-1202
info@de.hettich.com
www.hettich.com

DEUTSCHE SALICE GMBH
Rudolf-Diesel-Str. 10
D-74382 Neckarwestheim
Tel.: +49 (0)7133 / 9807-0
Fax: +49 (0)7133 / 9807-16
info.salice@deutschesalice.de
www.deutschesalice.de

Netherlands

Iplex Europe B. V.
Vonderweg 14
NL-7468 DC ENTER
Tel.: +31 547 384 635
Fax: +31 547 384 637
www.ixel-group.com

Switzerland

Häfele Schweiz AG
Dammstrasse 29
CH-280 Kreuzlingen
Tel: +41 (0)71/686 82 00
Fax: +41 (0)71/686 82 82
info@haefele.ch
www.haefele.ch

Fastening materials (gluing):

Austria

Fassadenklebetechnik Klug GmbH
Zentrale
Julius-Tandler-Platz 6/15
A-1090 Wien
Tel.: +43 (0)676 / 727 1724
r.klug@fassadenklebetechnik.at
office@fassadenklebetechnik.at
www.fassadenklebetechnik.at

Germany

Walter Hallschmid GmbH&Co.KG
Wiesentraße 1
D-94424 Arnsdorf
Tel.: +49 (0) 8723 / 96 121
Fax: +49 (0) 8723 / 96 127
www.dichten-und-kleben.de

MBE GmbH
Siemensstraße 1
D-58706 Menden
Tel.: +49 (0)2373 / 17430-0
Fax: +49 (0)2373 / 17430-11
www.mbe-gmbh.de

Switzerland

SIKA Chemie GmbH
Tüffenwies 16-22
CH-8048 Zürich
Tel.: +41 (0) 1 / 436 40 40
Fax: +41 (0) 1 / 270 52 39
www.sika.ch

Further adhesive suppliers:

SIKA Österreich GmbH
Lohnergasse 3
A-1210 Wien
Tel.: +43 (0)1 / 278 86 11
Fax: +43 (0)1 / 270 52 39
www.sika.at

DKS Technik GmbH
Gnadenwald 90A
A-6069 Gnadenwald
Tel.: +43 (0)5223 / 48 488-12
Fax: +43 (0)5223 / 48 488-50
www.dks.at

INNOTEC Industries Vertriebsgmbh
Boden 35
A-6322 Kirchbichl
Tel.: +43 (0) 5332 / 71138
Fax: +43 (0) 5332 / 72891
www.innotec.at

SOUDAL N.V.
Olof-Palme-Str. 13
D-51371 Leverkusen
Tel.: +49 (0) 214 / 6904-0
Fax: +49 (0) 217 / 6904-23
www.soudal.com

Profiles/accessories:

Austria

Protektor Bauprofile GmbH
Hosnedlgasse 12
A-1210 Wien
Tel.: +43 (0)1 / 259 45 00-0
Fax: +43 (0)1 / 259 45 00-19
www.protektor.com

Fa. Helmut Lohr
Elisabethstraße 36
A-2380 Perchtoldsdorf
Tel.: +43 (0)699 / 11506880
Fax: +43 (0)1 / 867 48 29
info@lohrshop.com

Germany

Protektorwerk
Florenz Maisch GmbH & Co.KG
Viktoriastraße 58
D-76571 Gaggenau
Tel.: +49 (0)7225 / 977-0
Fax: +49 (0)7225 / 977-111
www.protektor.com

Correctors (paints):

Austria

VOTTELER Lacktechnik GmbH
Malvenstraße 7
A-4600 Wels
Tel.: +43 (0)7242 / 759-0
Fax: +43 (0)7242 / 759-113
at.info@votteler.com
www.votteler.com

Germany

Heinrich König & Co. KG
An der Rosenhelle 5
D-61138 Niederdorfelden
Tel.: +49 (0)6101 / 53 60-0
Fax: +49 (0)6101 / 53 60-11
info@heinrich-koenig.de
www.heinrich-koenig.de

FSG Schäfer GmbH
Boschstraße 14
D-48703 Stadtlohn
Tel.: +49 (0)2563 / 9395-0
Fax: +49 (0)2563 / 9395-25
verkauf@fsg-schaefer.de
www.fsg-schaefer.de

Wash basins



Fig. 167

Max Compact Interior panels and Max Compactforming elements are particularly suitable for furniture construction, bathroom fittings, office furniture, shop-fittings and a wide range of design applications.

Depending on the use, Max Compact Interior panels can be used in furniture construction using the standard adhesive systems to join or mount materials together or to clad a corresponding substructure.

Construction advice

FunderMax Compact Interior panels shrink at the release of moisture and expand upon the intake of moisture. These possible dimensional changes of the panels must be taken into consideration during the processing and construction process. Metal constructions change their dimensions according to variations in temperature. However, the dimensions of Compact panels change under the influence of varying degrees of relative air moisture. These dimensional changes of structures and panels can work in opposing directions. Therefore, it is important to ensure sufficient expansion room during the mounting process.

A rule of thumb for the required expansion clearance is: 2 mm/metre

■ Due to the material characteristics, it is imperative that during the adhesion process of FunderMax Compact Interior panels to one another (corner joints, stumps or bevel cuts), all bonded parts have the same fibre direction. This means that attachments should be made solely length to length and breadth to breadth. The remaining panels must always indicate the production direction. Corner joints must be mechanically supported through the use of dowels, springs, special milling procedures etc.

■ For high levels of moisture a mechanical connection of joints is indispensable when combined with an elastic and watertight bonding adhesive system.

■ Throughout the construction and mounting process it is particularly important to ensure that the material is not exposed to stagnated moisture. The panel material must always be able to dry out. For use in wet rooms e.g. bathrooms, a sufficient ventilation system in the room is important.

■ If FunderMax Compact Interior panels are set apart from the substructure, they must be protected against corrosion (rotting).

■ Visible edges, or edges within reach must be bevelled or at least sanded down using sand paper in order to prevent injuries or damages to the material.

We do not recommend to mill the surface of Compact with white core to maintain the perfect cleanability.

The same logically applies to Max Compactforming elements. Due to the formable laminate layer, particular care must be taken when selecting the field of use and the production process. Please consult our application engineers. We reserve the right to make changes in line with technical progress.



Fig. 168

Installation possibilities for wash basins using Max Compact panels or Max Compactforming elements

The higher the raised edges, the higher the bearing capacity (stiffness) of Max Compactforming elements. If the shafts are shortened, they should not be cut back under the dimensions: Inner radius + thickness + 15 mm. This essentially means that an element that is at least 15 mm wide, must remain as such after the rounding process.

Please take note of the tolerance values of Max Compactforming elements, you will find this in a valid delivery programme.

The simple solution:

Cutting out/screwing in an 'insertable wash basin'

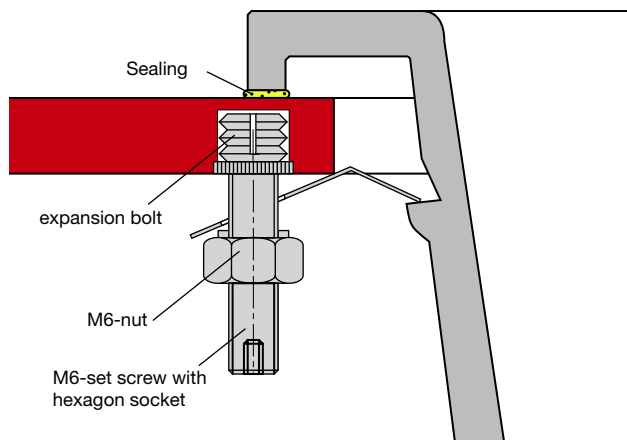

Fig. 169

The rational solution:

The milling of Max Compact forming elements and the unscrewing of the built-in wash basin. For high quantities of components, the milling can be done with a table router using templates.

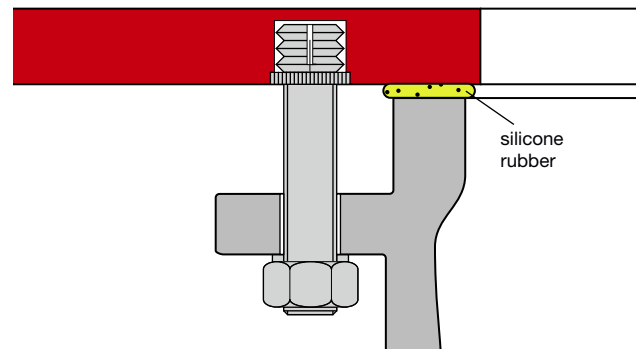

Fig. 170

Note: Max Compact Interior panels with white core are not recommended for use with bathroom or kitchen furniture because their milled edges may be easier become soiled.

The elegant solution:

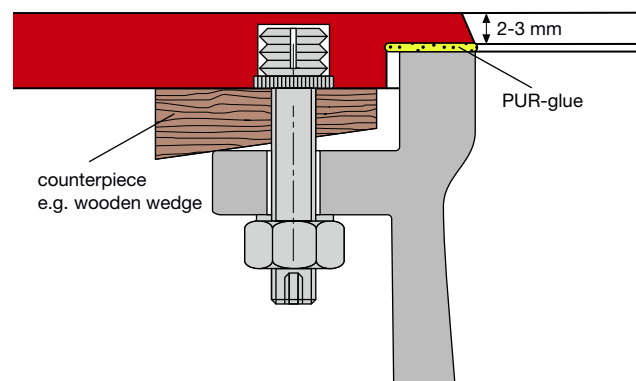

Fig. 171

Wash basins

The mounting of an in-built wash basin in a rabbeted Max Compactforming element.

This process is described as follows:



1. Draw the cut-out and cut out with a miller

Fig. 172



4. Mill the projection of the Compact Laminates flush on the visible side with a manual surface miller (angled miller!).

Fig. 175



2. Rebate from the underside of the Compactforming Element with a rod miller or CNC machining centre.

Fig. 173



5. Fine clean and finish off with a scraper and sandpaper.

Fig. 176



3. Glue the basin in with PUR glue and screw in as in the diagram.

Fig. 174

Help for orders and part lists of Max Compactforming Elements you will find in our download area at our website www.fundermax.at



Fig. 177

Recommendation for the production of sandwich elements with Max Compact panels

The production of sandwich elements takes place:

- Through direct moulding into suitable technical devices.
- Through gluing of the core material on the one sanded side of the Max Compact panels. This type of sandwich element is also simple for craftsmen to carry out.

Core materials

- Polystyrene hard foam panels (XPS or EPS)
- Rigid polyurethane foam panels
- Mineral wool panels (high density necessary)

Advantages and applications

- Decorative surfaces with high insulation values can be achieved
- Stable and light-weight door elements

Important information

Max Compact panels must be processed in the same direction on both sides (production direction - there is twice as much swelling and shrinkage behaviour in a horizontal panel direction than there is vertically). Max Compact panels must be conditioned before adhering. As a timeframe for sufficient conditioning (normal workshop temperature) a period of 7-14 days should be given, depending on the panel thickness. Before the adhesion process, the adhesive surfaces must be degreased and dust-free. If there are no machine application devices available, a notched trowel can be used.

The applied quantity is stipulated by the adhesive manufacturer. Foams with a certain elasticity compensate for different changes in length e.g. for variations of temperature inside and outside.

Adhesives

Solvent-free reactive adhesives such as polyurethane or epoxy resin e.g. ICEMA R 145/44 or ICEMA R 145/12 of the company H.B. Fuller Austria GmbH-DI-NITROL 517 A/B or ICEMA 101/25 + Härter 7 DKS Technik GmbH

Advice

Not every adhesive can be removed from the panels. Own test samples using glue must be carried out before the process begins. Under all circumstances, please adhere to the processing regulations provided by the adhesive manufacturer. For the protection of the surfaces, protective films must be left on the panels. When using hot-melt adhesives, do not exceed 60° C.

Mounting

Sandwich elements with Max Compact panels should be mounted with sufficient room for expansion (2 mm/metre) built into a rotating frame structure. It is imperative that stagnated moisture within the frame profile is avoided. Frame drainage and glazing blocks shall be provided. For late grouting use the weather side with glazing tapes. It must be ensured that the rebated moulds are sufficiently stable to be able to fasten mechanically (screws, nails, rivets etc) so that they remain firmly intact even under occasional tensions for e.g. wind pressure. The mounting process must at least correspond to that of the laminate glass. Different uses for the sandwich elements with Compact Interior and System wall dividers (e.g. offices) include: gate, door or window parapet panels, infill panels for wall dividers, vehicle construction and containers, trade fairs and cold storage cells.

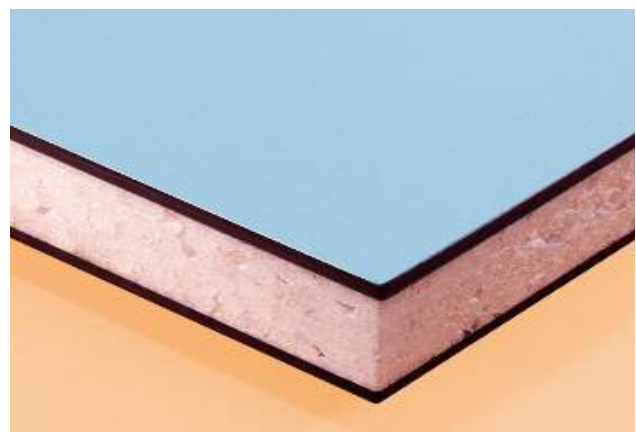

Fig. 178



Fig. 179

General information

FunderMax Compact panels und Max Compact forming elements can be mounted in different ways onto railings and balustrades. They can be screwed or riveted onto a supporting structure and they can also be fixed using glass clamps.

FunderMax Compact Interior panels shrink at the release of moisture and expand upon the intake of moisture. These possible dimensional changes of the panels must be taken into consideration during the processing and construction process. Metal constructions change their dimensions according to variations in temperature. However, the dimensions of Compact panels change under the influence of varying degrees of relative air moisture. These dimensional changes of structures and panels can work in opposing directions. Therefore, it is important to ensure sufficient expansion space during the mounting process. As a rule of thumb, a necessary expansion room of: 2 mm/metre applies.

Hole pattern

For holes in FunderMax Compact Interior panels we recommend using Max Alucompact42 panels for fall protection. Also see processing recommendations on page 29.

Construction advice

- FunderMax Compact Interior panels should only ever be mounted as infill panels for supporting substructures.
- Throughout the construction and mounting process it is particularly important to ensure that the material is not exposed to stagnated moisture. The panel material must always be able to dry out.
- Due to the material characteristics, it must thoroughly be ensured that during the adhesion process of FunderMax Compact Interior panels to one another (corner joints, stumps or bevel cuts), all bonded parts have the same production direction. This means that attachments should be made solely length to length and breadth to breadth. The remaining panels must always indicate the production direction.
- The substructure must be protected against corrosion (rotting).
- All edges within reach must be sanded, v-joints form between the panel joints.

The same logically applies for **Max Compactforming elements**. Due to the formable panel construction particular care must be taken when selecting the field of application and the production process



Fig. 180

Please talk to our application engineers. We reserve the right to make changes that affect technical progress.

Fastening points

There are almost always 3 fastening points in every direction. Structural evidence must be shown. The stability of the railing will be guaranteed by the processor. We would like to point out, that this information relates to height distances and can only be used for flawless connections. Adequate screw and rivet dimensions must be adhered to.

Please take note: In our brochure 'Compact Exterior Technology' we demonstrate different mounting possibilities for railings with compact panels, which have all been tested and approved by the 'ETB guidelines for structural elements that protect against falls' (from 6.1.85).

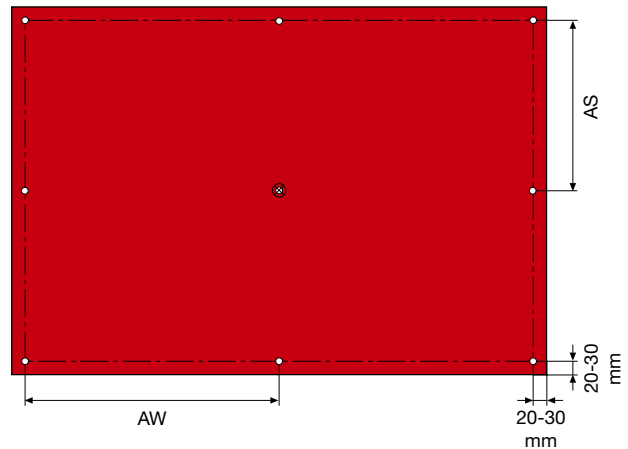

Fastening spacings
⊗ Fixed point

Fig. 181

Fastening spacings for screwed and riveted joints

Max Compact Panel Thickness in mm	AW/AS
8	< 400 mm
10	< 500 mm

Table 23

Fastening spacings for clamping plates

Max Compact Panel Thickness in mm	AW	AS
8	< 900 mm	< 400 mm
10	< 1100 mm	< 500 mm

Table 24

Suppliers/accessories for railings

Various accessories:

Schachermayer Großhandels-gesellschaft mbH
Schachermayerstr. 2-10
A-4021 Linz
Tel.: +43 (0)732 / 6599 - 0
Fax: +43 (0)732 / 6599 - 1360
zentrale@schachermayer.at
www.schachermayer.at

SWS Ges. f. Glasbaubeschläge
Friedrich-Engels-Straße 12
Tel.: +49 (0)2291 / 7905-0
Fax: +49 (0)2291 / 7905-10
D-51545 Waldbröl
info@sws-gmbh.de
www.sws-gmbh.de

SCHÜCO International KG
Karolinenstraße 1-15
D-33609 Bielefeld
Tel.: +49 (0)521 / 7830
Fax: +49 (0)521 / 78 34 51
info@schueco.com
www.schueco.com

Hueck + Richter Aluminium GmbH
Rossakgasse 8
A-1230 Wien
Tel.: +43 (0)1 / 667 15 29-0
Fax: +43 (0)1 / 667 15 29-0
www.hueck.at

Lauterbach GmbH
Heraeusstraße 22
D-06803 Bitterfeld-Wolfen/OT Greppin
Tel.: +49 (0)3493 / 82 76 76
Fax: +49 (0)3493 / 92 29 06
info@lauterbach-gmbh.com
www.lauterbach-gmbh.com

NORMBAU
Beschläge und Ausstattungs GmbH
Schwarzwaldstrasse 15
D-77871 Renchen
Tel.: +49 (0)78 43 / 7 04-0
Fax: +49 (0)78 43 / 7 04-43
info@normbau.de
www.normbau.de

Pauli + Sohn GmbH
Eisenstraße 2
D-51545 Waldbröl
Tel.: +49 (0)2291 / 9206-0
Fax: +49 (0)2291 / 9206-681
www.pauli.de

ALUKÖNIGSTAHL GmbH
Goldschlagstrasse 87-89
A-1150 Wien
Tel.: +43 (0)1 / 98 130-0
Fax: +43 (0)1 / 98 130-64
office@alukoeningstahl.com
www.alukoeningstahl.com

HEWI Heinrich Wilke GmbH
Prof.-Bier-Straße 1-5
D-34454 Bad Arolsen
Telefon: +49 5691 82-0
Telefax: +49 5691 82-319
info@hewi.de
www.hewi.de

You will find examples of fastening varieties on the following page ➔

Railings

Fastening varieties

a) Direct fastening using blind rivets with flat round-head of 5.0 x 21 stainless steel and rivet washers NR 8; inner diameter 5.1 mm. Set rivets with hinge tips.

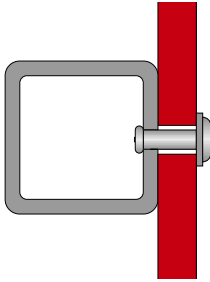

Variant a

Fig. 182

b) Mounting devices screwed to the railing tube (e.g.: Schüco, Alu König Stahl, Längle)

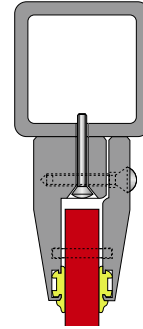

Variant b

Fig. 183

c) Welded steel handles with raised counter-sunk head screws M6 x 20 DIN 964 and cap nut M6 DIN 1587 (stainless steel).

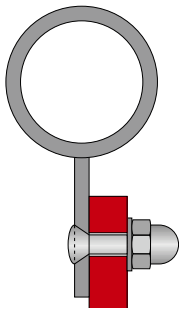

Variant c

Fig. 184

d) Welded steel handles with two clamping plates and hexagon bolts M6 x 25 DIN 933, cap nut M6 DIN 1587 and sheets M6 DIN 121 A (stainless steel).

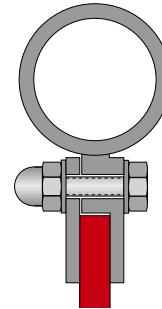

Variant d

Fig. 185

e) Mounting of Max Compact panels and Max Compactforming Elements with pairs of circular plates \varnothing ... mm; 5 mm thick.

The base plates are welded to aligned projections jutting from vertical rail stanchions. The cover plates are screwed with 2 stainless steel countersunk screws (M6 x 20 DIN 963) through the drill holes in the Max Compact panel (expansion clearance!) to the base plates.

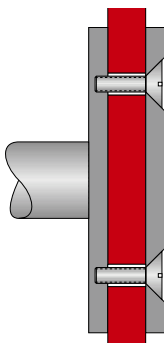

Variant e

Fig. 186

FunderMax France
3 Cours Albert Thomas
F-69003 Lyon
Tel.: +33 (0) 4 78 68 28 31
Fax: +33 (0) 4 78 85 18 56
infofrance@fundermax.at
www.fundermax.at

FunderMax Spain
Pol. Ind. Can Salvatella Avda. Salvatella,
85-97
E-08210 Barberà del Vallès (Barcelona)
Tel.: +34 93 729 63 45
Fax: +34 93 729 63 46
info.spain@fundermax.biz
www.fundermax.es

FunderMax India Pvt. Ltd.
No. 13, 1st Floor, 13th Cross
Wilson Garden
IND-560027 Bangalore
Tel.: +91 80 4112 7053
Fax: +91 80 4112 7053
officeindia@fundermax.biz
www.fundermax.at

FunderMax Polska Sp. z o.o.
ul. Rybitwy 12
PL-30722 Kraków
Tel.: +48-12-65 34 528
Fax: +48-12-65 70 545
infopoland@fundermax.biz

FunderMax Swiss AG
Industriestrasse 38
CH-5314 Kleindöttingen
Tel.: +41 (0) 56-268 81 31
Fax: +41 (0) 56-268 81 10
infoswiss@fundermax.biz
www.fundermax.ch

FunderMax North America, Inc.
2015 Ayrslay Town Blvd. Suite 202
Charlotte, NC 28273, USA
Tel.: +1 704 280 8490
Fax: +1 704 280 8301
office.america@fundermax.biz
www.fundermax.at



FunderMax GmbH
Klagenfurter Straße 87-89
A-9300 St. Veit / Glan

Tel.: +43 (0) 5 / 9494- 0
Fax: +43 (0) 5 / 9494-4200
office@fundermax.at
www.fundermax.at

MEMBER OF *Constantia* INDUSTRIES